

## OPEN MEETING MINUTES

Instructions: [F-01922A](#)

|   |                            |                          |  |
|---|----------------------------|--------------------------|--|
| Name of Governmental Body:<br>Wisconsin Long Term Care Advisory Council (LTCAC) |                            |                          | Attending: Audra Martine, Beth Swedeen, Christine Witt, Cindy Bentley, Dennise Lavrenz, Denise Pommer, Elsa Diaz Bautista, Janet Zander, John Sauer, Kenneth Munson, LaVerne Jaros, Lea Kitz, Maureen Ryan, Shanna Jensen, Stacy Ellingen, Stephanie Birmingham, Shakita LaGrant, Beth Fields, Michael Bruhn |
| Date: 1/11/2022   | Time Started:<br>9:30 a.m. | Time Ended:<br>2:00 p.m. |  |
| Location: Virtual Zoom Meeting  |                            |                          | Presiding Officer: Heather Bruemmer  |

### Minutes

**Members absent:** Audrey Nelson and Darci Knapp

**Others present:** Brenda Bauer, Carrie Molke, Curtis Cunningham, Kevin Coughlin, Kiva Graves, Krista Willing, Tom Balsley, Karen Timberlake, Lisa Olson, Paula Tran, Jonette Arms, Anna Benton, Kimberly Schindler

#### Meeting Call to Order, presented by Heather Bruemmer

- Went over meeting processes.
- Introductions of present council members and Department of Health Services (DHS) staff were made
- Approval of November 2021 Meeting Minutes
  - Motion to approve by Dennise Lavrenz. Seconded by Cindy Bentley. Unanimously approved

#### Division of Medicaid Services (DMS) Updates, presented by Curtis Cunningham

- The telehealth permanent policy has been published in ForwardHealth and will go into effect once the public health emergency is rescinded.
- The Home and Community Based Settings (HCBS) Statewide Transition Plan (STP) was submitted to CMS for approval.
- Electronic Visit Verification (EVV)
  - Hard launch was delayed. CMS would like a new hard launch date and plan soon.
  - DHS looking at what needs to be accomplished to assure a high level of compliance and a fair opportunity for people to enter and use the system.
- Children's Long Term Support Waiver (CLTS)
  - The waiver was approved by CMS with the additional benefits.
  - There are now over 12,000 children on the waiver.
- There will be a lot of pandemic unwinding work. Due to the public health emergency (PHE), we have not been disenrolling individuals. When the PHE ends, we will be required to do eligibility reviews for everyone, including the long-term care functional screen (LTCFS). The goal for DHS is if an individual is found no longer eligible for Medicaid, there is a smooth transition to assure people do not go without health insurance.
- American Rescue Plan Act (ARPA)
  - DHS will have until March 2024 to spend the enhanced funding. DHS website updated today with more information. There will also be a listserv and general mailbox for ARPA related questions.
  - Krista will talk about 5% rate increase this afternoon.
  - Direct care workforce reform will look at career ladders, statewide directory for direct care workers, staff stability survey. Currently reviewing potential surveys and looking into ways to gather responses. Hope to have an initial survey out to providers sometime in 2022.

- Completed review with tribes to look at their HCBS systems and how they would like to use the funding to enhance services for their individual tribes.
- ADRC outreach and education; enhanced marketing and systems for ADRCs.
- Service provider innovation grants – we are getting the administrative structure up and running. May be a great conversation for the next LTCAC meeting. We are considering phasing in the program as we do not have the capacity to process all grants at one time.
- **Council Suggestion:**
  - Future agenda topic - update on the critical incident system to allow sharing between long-term care and adult protective services.

### **Division of Public Health (DPH) and Division of Medicaid Services (DMS) Administrators Introductions**

- New leadership in the Division of Public Health
  - New State Health Officer/Division Administrator- Paula Tran
  - Two new Assistant Division Administrators
    - Jonette Arms
      - Will manage and direct the Bureau of Aging and Disability Resources, Bureau of Communicable Diseases, Bureau of Community Health Promotion, and Bureau of Environmental and Occupational Health.
    - Anna Benton
      - Will manage and direct the Office of Policy and Practice Alignment, Office of Health Informatics, Office of Preparedness and Emergency Healthcare, and the Bureau of Operations.
- New leadership in the Division of Medicaid Services; new Medicaid Director/Division Administrator – Lisa Olson

### **Address to Council, presented by Karen Timberlake**

- Welcomed new council members.
- Reviewed 2022-2023 Charges to the LTCAC
- **Council Suggestion:**
  - As we look at charges, we will need to measure our success. As we move forward, it would be helpful for the council to have metrics to review on a regular basis.
  - Consider future agenda topic on state centers and any plans for closure.

### **Department of Public Health Updates (DPH), presented by Carrie Molke**

- A number of groups (ILCs, ADRCs, aging service providers) have contacted us to express concern with not having adequate resources to support them as they provide services.
  - Looking at impact of workforce on their services also. Much of the aging system is volunteer led and many volunteers stopped volunteering with the pandemic and agencies are having a hard time recruiting them back.
  - DHS is starting conversations with these agencies on how we can assist with the issue.
- **Council Suggestion:**
  - Look at opportunities to connect across multiple state agencies to address because workforce issues affect more than just DHS programs, such as transportation.
  - Consider a strategy such as community conversations to get non-traditional individuals involved. There is collective impact because these services are likely to touch everyone in Wisconsin at some point in their lives.
- COVID-19
  - Continue to see a high number of cases statewide and COVID continues to impact our work.

- 500 people have been deployed to assist with the nearly 300 facilities that made requests for assistance. First wave of National Guard has been deployed to assist skilled nursing facilities. The hope is that more beds can open to relieve stress on acute care and hospitals.
- Health Equity Grants
  - Over 60 organizations applied, 40 grant awards are available.
  - Grant awards will be announced the week of January 17, 2022.
- State Health Improvement Plan (SHIP)
  - The State Health Assessment (SHA) was recently completed, now starting on State Health Improvement Plan.
  - Looking to seek feedback from the aging and disability network. Just starting to flush out process and timeline. Will likely bring to LTCAC in the spring.
- Narrative Training
  - We need a better narrative for advocacy and community work as we know how important community organizing is; especially bring trusted voices from our communities into our work. If we hope to achieve better health equity, we need to get better about our narrative and addressing toxic narratives.
  - Looking to provide narrative training to staff.
  - Will be bringing this topic to the LTCAC for future meetings and discuss if council would like to receive narrative training also.
- Aging Plans
  - The plan process is robust. Plans are for three years and agencies are simultaneously working on their current plan and building one the next one.
  - Historically we have started with the State's plan; then to the aging unit; then to the counties. This time we flipped the process. Counties have completed their plans and have submitted them for review. Area Agencies on Aging have completed their plans, so now DHS is starting work on the State's plan.
  - Should have a draft in March; public comment period likely to be in early May.

### Public Comment

- Ramsey Lee
  - Thank you for your work. Would like to get more involved with the council and commitment to equity. How can I get more involved with the long-term care council?
  - Would like to see the state centers close so people can live in their own communities.
  - Appreciate the wage increases for personal care workers, but would like to see a similar increase for supportive home care workers. Everyone is having trouble recruiting caregivers.
- Bob and Heidi Sheire
  - Will the PHE be extended?
  - The council is doing an excellent job – wish I could be part of the committee.
- Jane Bushnell
  - Appreciative of the ARPA funding increases. Agencies did find out about this in late December when many staff were out over the holidays. New authorizations needed to be completed in a short timeframe and we are waiting on them. If a similar initiative occurs in the future, request that DHS work with stakeholders to implement in a doable timeframe.
- Jason Glozier
  - I will be the replacement for Maureen at the Wisconsin Coalition of Independent Living Centers director. I am encouraged by what has been discussed on the call today, especially inclusion. I am excited to work with the council.

- Larry
  - Caregivers need better wages and they also need benefits. Many people give their lives to improve the life of people with disabilities. The money being spent on DHS systems and infrastructure could be spent on additional increases to caregiver rates and benefit packages.

#### **American Rescue Plan Act (ARPA) – 5% Rate Increase, presented by Krista Willing**

- Feds allow us to use ARPA funding to have additional funds for HCBS expenses for a period of time
  - January 1, 2022 implementation for most programs. Working with HMOs and MCOs to pass the increase on to providers.
  - Due to self-direction with IRIS program, the implementation is based on conversations with IRIS participants so the roll-out will be longer.
  - The Governor’s budget had separate increases for self-directed personal care workers so the 5% increase is on top of the increase outlined in the budget.
- Press release on increase just went out. The DHS public page has more information including frequently asked questions.
- **Council Suggestions:**
  - When we track Bureau of Labor statistics, costs have gone up by almost 15%. In order for providers to survive and have staff, wages need to increase – so this increase is necessary but is not enough. DHS should consider investing more ARPA funding into caregiver wages and benefits.
  - Some council members are receiving emails about the March 2024 date for spending ARPA HCBS funding. When DHS is looking at developing rates, consider the cost of doing business as part of the need to sustain increases.
  - Hearing of providers closing doors, DHS should conduct a deeper dive of the MCO provider networks to assure they are accurate and offer choice.

#### **American Rescue Plan Act (ARPA) – HCBS Independent Living Pilot, presented by Curtis Cunningham and Carrie Molke**

- Under this initiative the Department will utilize ARPA HCBS funding to develop an independent living pilot. The intent of this initiative would be to divert individuals that would eventually be eligible for Medicaid home and community based services and delay entry into publically funded long term care. Diversion could also occur by providing the necessary supports to increase income. This pilot would be evaluated as a proof of concept to determine efficacy and cost effectiveness to determine adopting as part of the Medicaid program. Medicaid federal matching funds along with savings from diversions would demonstrate adding this program is a cost effective addition to the Medicaid program.
- Looking to LTCAC for thoughts on who should be eligible; what services should be provided; how should the program be administered; and any other considerations.
- **Council Suggestions:**
  - This is very exciting and makes sense. Part of it is thinking through getting the word out and reaching these individuals. Benefit package would need to be limited to be self-sustaining; cannot consider providing the entire LTC benefit package. Consider starting with eligibility for people living in their homes with caregivers. May consider benefits and funding for one-time costs vs. ongoing costs.
  - Agree there may be a need to limit the benefit package. Home repairs and home modifications are a huge need. Could consider eligibility for individuals with certain categories of disease/disability (such as diabetes) that we know can lead to greater care needs. Concern for using any type of income guideline for eligibility as income can change at any time.

- This is reminiscent of old Title 20 SHC program. That program funded SHC, transportation and one-time equipment needs. This program was administered by local aging units. Need to consider quick eligibility process to assure people get the help they need when they need it.
- DHS should consider looking to counties and tribal aging unite. These programs already serve people just above the poverty level and see lots of need for home repairs and modifications.
- DHS might want to consider benefits other than items. Sometimes people just need care management for a short time to figure out how to live independently. They might need help reviewing mail, figuring out budgets, etc.
- DHS might want to consider how those in non-licensed congregate settings might get some support as not everyone lives in a traditional home. Maybe a service coordinator to help people in the setting meet their needs.
- Consider using the current system to support/administer this program rather than looking at a new long-term care system to take on this pilot.
- Milwaukee County contacts out to provide some services to people not eligible for long-term care. More information on this program can be shared with DHS.
- Many counties run similar programs, need to think about what would happen to these programs if DHS pilots this program.
- Tribes have similar programs. No income limits, but have limit on funding amount available and only eligible every 4 years.
- Look into CAPABLE program.

#### **Council Business, presented by Heather Bruemmer**

- Next meeting March 8, 2022

#### **Adjourn**

- Motion to adjourn by Maureen Ryan. Motion seconded by Cindy Bentley. Approved unanimously.

Prepared by: Kimberly Schindler on 1/12/2022.

These minutes are in draft form. They will be presented for approval by the governmental body on: 3/8/2022



## Wisconsin Department of Health Services Charter for the Wisconsin Long Term Care Advisory Council

*Updated January 2022*

### **Background**

The Wisconsin Long Term Care Advisory Council was first created through the 1999 Wisconsin Act 9 with the responsibility to report annually to the legislature and to the Governor on the status of Family Care and assist in developing broad policy issues related to long-term care services. Wisconsin Act 9 sunset the Council as a legislative council as of July 21, 2001, but the council was reappointed a few months later as an advisory group to the Department on emerging issues in long-term care. The Council has continued to provide guidance to the secretary and make recommendations regarding long-term care policies, programs, and services.

### **Legal References to the Wisconsin Long Term Care Council**

As a DHS-established Secretary-appointed Council, in contrast to a statutory council, **Administrative Rule, Subchapter II – Aging and Disability Resource Centers, DHS 10.21[3]** makes the provision that the standard contract for Aging and Disability Resource Centers, “shall comply with all applicable state and federal laws and may be modified only in accordance with those laws and after consideration of the advice of...the secretary’s council on long-term care...”

### **DHS 10.42[6]**

(6) Except as provided in this subsection, the department shall use standard contract provisions for contracting with CMOs. The provisions of the standard contract shall comply with all applicable state and federal laws and may be modified only in accordance with those laws and after consideration of the advice of all of the following:

(a) The secretary's council on long-term care.

(b) The regional long-term care advisory committee appointed under s. [46.2825 \(1\)](#), Stats., serving the area in which an organization operates, or proposes to operate, a resource center.

(7) The department shall annually provide to the members of the secretary's council on long-term care copies of the standard CMO contract the department proposes to use in the next contract period and seek the advice of the council regarding the contract's provisions. The department shall consider any recommendations of the council and may make revisions, as appropriate, based on those recommendations. If the department proposes to modify the terms of the standard contract, including adding or deleting provisions, in contracting with one or more organizations, the department shall seek the advice of the council and consider any recommendations of the council before making the modifications.



### 1915(C) Family Care Waiver 6-I (Public Input)\*:

“A broad spectrum of stakeholders participated in the initial design of the Family Care program, including consumers, advocates, providers and their associations, legislators, county government and representatives of all State agencies involved in providing services to individuals with long term care needs.

In 2008, the Wisconsin Council on Long Term Care was convened by the Department of Health Services Secretary and was operated through 2012. Its mission was to advise the Department of Health Services (the SMA) on the statewide implementation of Family Care for elderly people and adults with disabilities. The Council had broad stakeholder representation and reserved time on each agenda to hear from the public on issues and concerns about the long term care system in Wisconsin.

In 2012, this council was replaced by the Wisconsin Long Term Care Advisory Council, which provides ongoing guidance to the SMA related to policies and operations of Wisconsin's long term care programs and statewide expansion of the Family Care program. The Council is comprised of individuals from multiple organizations and disciplines related to long term care, as well as consumer representatives. ~~The Council consists of: The Laureate Group, Wisconsin Assisted Living Association, Board on Aging and Long Term Care, ContinuUs, Community Care of Central Wisconsin, ADRC of Brown County, Oneida Tribe, Alzheimer's Association of Southeastern Wisconsin, Disability Rights Wisconsin, Greater Wisconsin Agency on Aging Resources, Milwaukee County Department of Family Care, Milwaukee County Department of Health and Human Services, Eau Claire School District, Wisconsin Health Care Association, ADRC of the North, ADRC of Winnebago County, Wisconsin County Human Services Association (WCHSA), Brain Injury Alliance of Wisconsin, Independence First, WI Coalition of Independent Living Centers, LeadingAge Wisconsin, Richland County Aging and Disability Board, Milwaukee County Department of Aging, Board for People with Developmental Disabilities, Milwaukee County Commission on Aging, Advanced Employment, and consumer and member representatives.~~ Council members serve for 3 years, on staggered terms. The Council reserves time on each agenda to hear from the public on issues and concerns about the long term care system in Wisconsin. This group of stakeholders continues to provide feedback to the SMA on a regular basis.”

*\*Note: Due to changes in the make-up of the council, the Department is determining if a waiver amendment is necessary.*

### Charge

On an annual basis, the Office of the Secretary shall issue charges for the Council to address. The term and length of the charge will be determined by the Secretary. Annually, the charges



~~will be appended to this document~~ are updated on the Long-Term Care Advisory Council website at: <https://www.dhs.wisconsin.gov/wltcac/index.htm>. -

## Membership

The Secretary appoints the Council members and the Chair and Vice Chair of the Council. Members serve at the discretion of the Secretary or for three-year terms, as specified in the letter of appointment. Terms are on a calendar year basis. Members of the Council include long-term care advocates, consumers, providers, and contractors. The Secretary may also appoint experts as necessary.

The Council shall meet bimonthly (every other month). In order for the Council to have continuity and to carry out its business, members are expected to be in attendance at Council meetings. Members may send a substitute to observe from the gallery, though substitutions do not count toward the 4-meeting attendance minimum per 12-month period. If a member misses two or more meetings within a 12-month period, the Chair will notify the Secretary to determine if the Secretary will replace the member.

The Assistant Administrator of Long Term Care Benefits and ~~Programs~~ [Service Delivery](#) within the Division of Medicaid Services, will act as the council liaison for DHS.

## Responsibilities

The Council is responsible for providing advice regarding the provision of Long Term Care services in Wisconsin. This includes both publicly funded and privately funded services. The Council is responsible for providing advice to the Secretary in regards to the Council charges. The Council advice will be summarized into advisory documents for the Secretary. The Chair will be responsible for meeting with the Secretary to provide the advisory document and deliver the Secretary's response as necessary.

At the end of each meeting, the Council will propose agenda items for future meetings. If agenda items arise between meetings, members may contact the Council Chair or the DHS liaison. The Council Chair and the DHS liaison will finalize the agenda and distribute it to members one week in advance of the meeting.

The Council will set aside time on each agenda for public comments. All individuals wishing to address the Council will be asked to identify themselves ~~on a sign-in sheet~~ in advance of ~~the meetings~~ [speaking](#), with their name and the name of any organization that they represent. The Chair will make every effort to respect individuals from the public, while keeping the input brief





and to the point, in order to facilitate an efficient meeting process.

Council members who are not State employees may claim travel-related cost reimbursement for Council sponsored meetings. All travel claims must be submitted on the State-provided travel voucher forms and will be reimbursed at State rates. Before any claim can be processed, the member must have a W-9 Taxpayer Identification Number Verification form on file. To assist members in receiving state rates at hotels, DHS/~~DLTC~~DMS staff will assist in making reservations and having costs direct-billed if possible.



## **Appendix A**

### **Council Charges January 2022 – December 2023**

During the period of January 2022 to December 2023, Secretary designee Timberlake is charging the Long Term Care Advisory Council (LTCAC) with the following:

#### **Charge 1: — Long Path**

Planning and problem-solving strategy looking ahead 10, 15, 25, and 100 years. Develop a collaborative and innovative strategic plan visualizing a future based on shared values and beliefs on what Wisconsin's long term care system will look like.

#### **Charge 2: — Medicaid Long Term Care—**

Explore strategies to ensure Wisconsin's Long Term Care (LTC) programs focus on the whole person including: access; choice; high quality; collaborative relationships; efficient and cost-effective; with Wisconsin leading the nation in LTC delivery and services and supports.

- Provide advice and guidance on the number of Geographic Service Regions (GSRs).
- Provide advice and guidance on the number of Managed Care Organizations (MCOs), IRIS Consultant Agencies (ICAs), and Fiscal Employer Agents (FEAs) in each GSR.
- Provide advice on procurement strategies for MCOs and ICAs.
- Provide advice on benefit definitions, reimbursement models, rates, and value based purchasing strategies.
- Provide advice and guidance on integrating or aligning long term care services with behavioral health services and acute and primary care services, including services provided through Medicare
- Provide advice and guidance on the spending of American Rescue Plan (ARPA) Act of 2021 Section 9817 funds in regards to enhancing and improving home and community based services.
- Provide advice and guidance on access to and quality in long term care programs.

#### **Charge 3: — Transportation**

Explore strategies to coordinate transportation in a more efficient and effective manner to improve access for medical, non-medical and social activities.

- Provide advice on the option of a Transportation Summit to bring together the Department of Transportation (DOT), Department of Health Services (DHS), Department of Workforce Development (DWD), tribes and key stakeholders.
- Explore the transportation activities of other councils and Departments.
- Explore ways to coordinate transportation rides and funding strings to develop a new strategy to improve effectiveness.
- Explore transportation to help caregivers reach consumers.



#### **Charge 4: Health Equity**

Develop strategies so everyone in Wisconsin's Long Term Care programs has a fair and just opportunity to be as healthy as possible. Explore strategies to remove obstacles to health such as poverty, discrimination, and their consequences, including powerlessness and lack of access to good jobs with fair pay, quality education and housing, safe environments, and health care.

- Provide advice and guidance on a cultural competency toolkit.
- Provide advice and guidance on how to ensure access to technology is equitable.
- Explore how the council can work with Division of Public Health (DPH) related to Wisconsin State Health Assessment.

#### **Charge 5: Workforce**

Develop recommendations to support and strengthen the direct care workforce, both paid and unpaid, to ensure access to care, improve the quality of caregiving, and meet the growing demand for long-term care services in Wisconsin, by:

- Studying the recommendations of the Governor's Task Force on Caregiving, providing advice and guidance on items that are being implemented and prioritizing recommendations for future consideration.
- Providing advice and guidance on proposals that relate to the direct care workforce and family/informal caregiving within the American Rescue Plan (ARPA) Act of 2021 Section 9817 to enhance, expand, or strengthen HCBS under the Medicaid program in Wisconsin.

On an annual basis, the Long Term Care Advisory Council (LTCAC) will make recommendations for the upcoming charges.



## Appendix B CY 2022 Council Membership

### 1 Council Chair Seat

| Status         | Name             | Organization                    |
|----------------|------------------|---------------------------------|
| Term Ends 2022 | Heather Bruemmer | Board on Aging & Long Term Care |

### 4 Advocate Seats

| Status         | Name                     | Organization                                     |
|----------------|--------------------------|--|
| Term Ends 2022 | Beth Swedeen             | Board for People with Developmental Disabilities |
| Term Ends 2022 | Sam Wilson/AARP Director | AARP   |
| Term Ends 2023 | Maureen Ryan             | WI Coalition of Independent Living Centers       |
| Term Ends 2024 | Lea Kitz                 | Disability Rights Wisconsin                      |

### 4 Consumer Seats

| Status         | Name                 | Organization              |
|----------------|----------------------|---------------------------|
| Term Ends 2022 | Stacy Ellingen       | IRIS Participant          |
| Term Ends 2022 | Cindy Bentley        | People First of Wisconsin |
| Term Ends 2023 | LaVerne Jaros        | Retired                   |
| Term Ends 2023 | Stephanie Birmingham | Consumer                  |

### 4 Contractor Seats

| Status         | Name            | Organization                         |
|----------------|-----------------|--------------------------------------|
| Term Ends 2022 | Janet Zander    | Greater WI Agency on Aging Resources |
| Term Ends 2022 | Shanna Jensen   | TMG                                  |
| Term Ends 2022 | Kenneth Munson  | Community Care, Inc.                 |
| Term Ends 2024 | Shakita LaGrant | DDHS of Milwaukee County             |

### 5 Expert Seats

| Status         | Name            | Organization                    |
|----------------|-----------------|---------------------------------|
| Term Ends 2022 | Dennise Lavrenz | MCFI                            |
| Term Ends 2022 | Denise Pommer   | DHS                             |
| Term Ends 2023 | Audra Martine   | La Crosse County Human Services |
| Term Ends 2024 | Beth Fields     | University of Wisconsin—Madison |
| Term Ends 2024 | Michael Bruhn   | Alzheimer's Association         |

### 5 Provider Seats

| Status         | Name               | Organization                            |
|----------------|--------------------|---|
| Term Ends 2022 | Darei Knapp        | Lori Knapp Companies                    |
| Term Ends 2023 | Audrey Nelson      | Wisconsin Brain Injury Advisory Council |
| Term Ends 2023 | Christine Witt     | Advanced Employment, Inc.               |
| Term Ends 2023 | John Sauer         | LeadingAge Wisconsin                    |
| Term Ends 2023 | Elsa Diaz Boutista | Alianza Latina                          |



*\* While member types have been established in certain categories, it is recognized that members may have multiple roles. All members should provide comprehensive input regardless of member assignment type and organizational affiliation. \_\_\_\_\_*



## Wisconsin Department of Health Services Charter for the Wisconsin Long Term Care Advisory Council

*Updated January 2022*

### **Background**

The Wisconsin Long Term Care Advisory Council was first created through the 1999 Wisconsin Act 9 with the responsibility to report annually to the legislature and to the Governor on the status of Family Care and assist in developing broad policy issues related to long-term care services. Wisconsin Act 9 sunset the Council as a legislative council as of July 21, 2001, but the council was reappointed a few months later as an advisory group to the Department on emerging issues in long-term care. The Council has continued to provide guidance to the secretary and make recommendations regarding long-term care policies, programs, and services.

### **Legal References to the Wisconsin Long Term Care Council**

As a DHS-established Secretary-appointed Council, in contrast to a statutory council, **Administrative Rule, Subchapter II – Aging and Disability Resource Centers, DHS 10.21[3]** makes the provision that the standard contract for Aging and Disability Resource Centers, “shall comply with all applicable state and federal laws and may be modified only in accordance with those laws and after consideration of the advice of...the secretary’s council on long-term care...”

### **DHS 10.42[6]**

(6) Except as provided in this subsection, the department shall use standard contract provisions for contracting with CMOs. The provisions of the standard contract shall comply with all applicable state and federal laws and may be modified only in accordance with those laws and after consideration of the advice of all of the following:

(a) The secretary's council on long-term care.

(b) The regional long-term care advisory committee appointed under s. [46.2825 \(1\)](#), Stats., serving the area in which an organization operates, or proposes to operate, a resource center.

(7) The department shall annually provide to the members of the secretary's council on long-term care copies of the standard CMO contract the department proposes to use in the next contract period and seek the advice of the council regarding the contract's provisions. The department shall consider any recommendations of the council and may make revisions, as appropriate, based on those recommendations. If the department proposes to modify the terms of the standard contract, including adding or deleting provisions, in contracting with one or more organizations, the department shall seek the advice of the council and consider any recommendations of the council before making the modifications.



### **1915(C) Family Care Waiver 6-I (Public Input)\*:**

“A broad spectrum of stakeholders participated in the initial design of the Family Care program, including consumers, advocates, providers and their associations, legislators, county government and representatives of all State agencies involved in providing services to individuals with long term care needs.

In 2008, the Wisconsin Council on Long Term Care was convened by the Department of Health Services Secretary and was operated through 2012. Its mission was to advise the Department of Health Services (the SMA) on the statewide implementation of Family Care for elderly people and adults with disabilities. The Council had broad stakeholder representation and reserved time on each agenda to hear from the public on issues and concerns about the long-term care system in Wisconsin.

In 2012, this council was replaced by the Wisconsin Long Term Care Advisory Council, which provides ongoing guidance to the SMA related to policies and operations of Wisconsin's long term care programs and statewide expansion of the Family Care program. The Council is comprised of individuals from multiple organizations and disciplines related to long term care, as well as consumer representatives. Council members serve for 3 years, on staggered terms. The Council reserves time on each agenda to hear from the public on issues and concerns about the long-term care system in Wisconsin. This group of stakeholders continues to provide feedback to the SMA on a regular basis.”

*\*Note: Due to changes in the make-up of the council, the Department is determining if a waiver amendment is necessary.*

### **Charge**

On an annual basis, the Office of the Secretary shall issue charges for the Council to address. The term and length of the charge will be determined by the Secretary. Annually, the charges are updated on the Long-Term Care Advisory Council website at:

<https://www.dhs.wisconsin.gov/wltcac/index.htm>.

### **Membership**

The Secretary appoints the Council members and the Chair and Vice Chair of the Council. Members serve at the discretion of the Secretary or for three-year terms, as specified in the letter of appointment. Terms are on a calendar year basis. Members of the Council include long-term care advocates, consumers, providers, and contractors. The Secretary may also appoint experts as necessary.



The Council shall meet bimonthly (every other month). In order for the Council to have continuity and to carry out its business, members are expected to be in attendance at Council meetings. Members may send a substitute to observe from the gallery, though substitutions do not count toward the 4-meeting attendance minimum per 12-month period. If a member misses two or more meetings within a 12-month period, the Chair will notify the Secretary to determine if the Secretary will replace the member.

The Assistant Administrator of Long-Term Care Benefits and Service Delivery within the Division of Medicaid Services will act as the council liaison for DHS.

### **Responsibilities**

The Council is responsible for providing advice regarding the provision of Long-Term Care services in Wisconsin. This includes both publicly funded and privately funded services. The Council is responsible for providing advice to the Secretary regarding the Council charges. The Council advice will be summarized into advisory documents for the Secretary. The Chair will be responsible for meeting with the Secretary to provide the advisory document and deliver the Secretary's response as necessary.

At the end of each meeting, the Council will propose agenda items for future meetings. If agenda items arise between meetings, members may contact the Council Chair or the DHS liaison. The Council Chair and the DHS liaison will finalize the agenda and distribute it to members one week in advance of the meeting.

The Council will set aside time on each agenda for public comments. All individuals wishing to address the Council will be asked to identify themselves in advance of speaking, with their name and the name of any organization that they represent. The Chair will make every effort to respect individuals from the public, while keeping the input brief and to the point, in order to facilitate an efficient meeting process.

Council members who are not State employees may claim travel-related cost reimbursement for Council sponsored meetings. All travel claims must be submitted on the State-provided travel voucher forms and will be reimbursed at State rates. Before any claim can be processed, the member must have a W-9 Taxpayer Identification Number Verification form on file. To assist members in receiving state rates at hotels, DHS/DMS staff will assist in making reservations and having costs direct billed if possible.



# DHS - Division of Medicaid Services

Updated February 2022

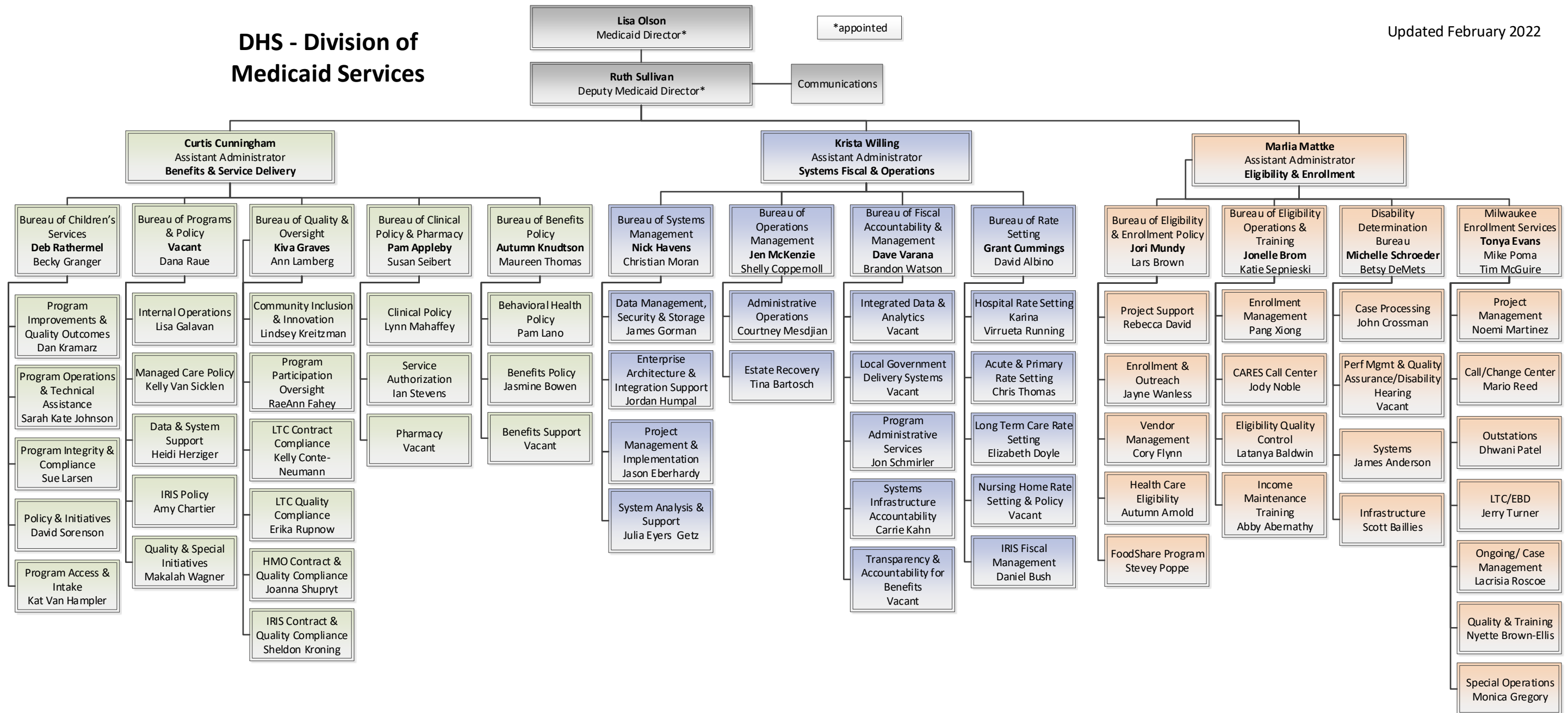

June 2021

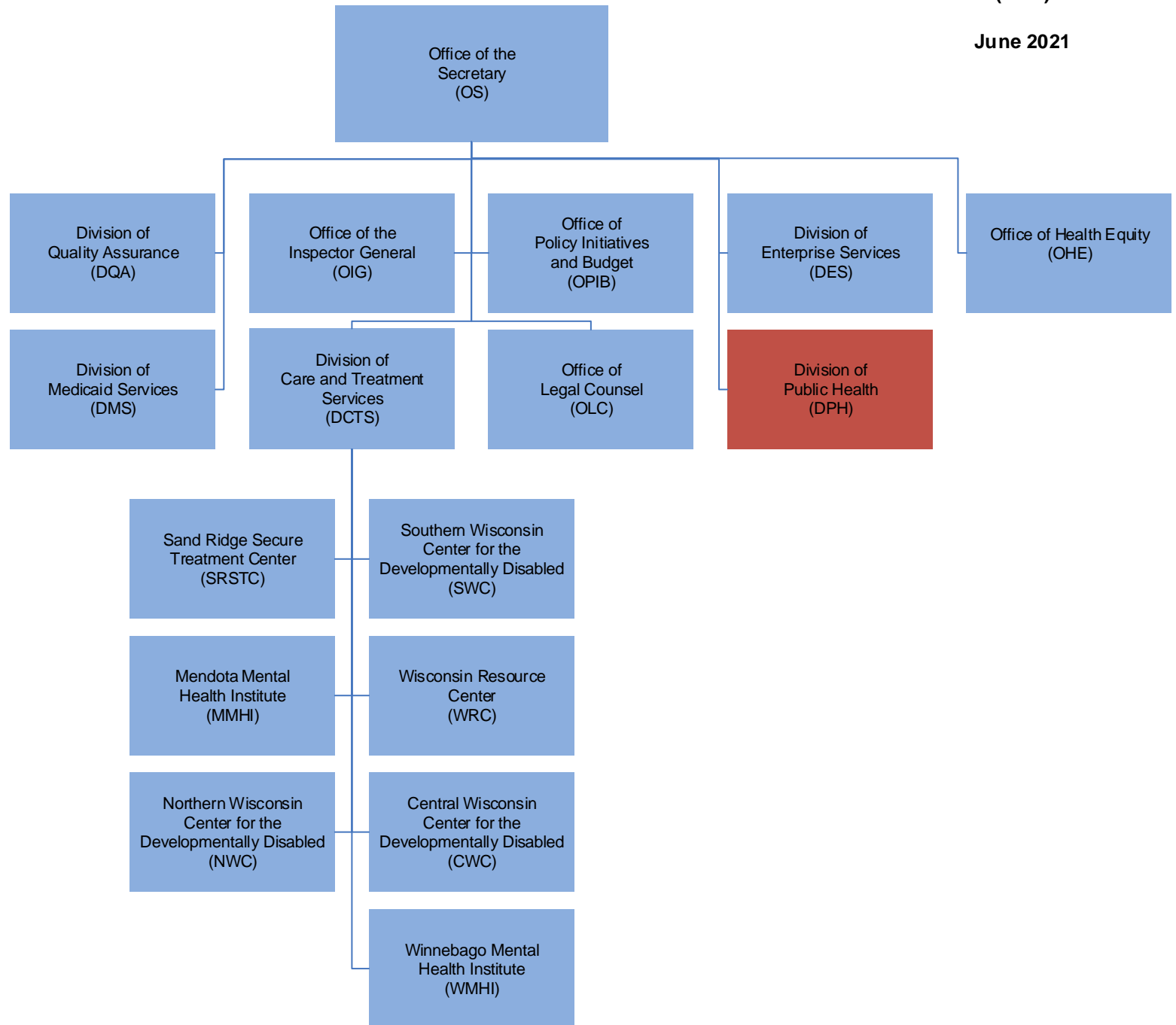

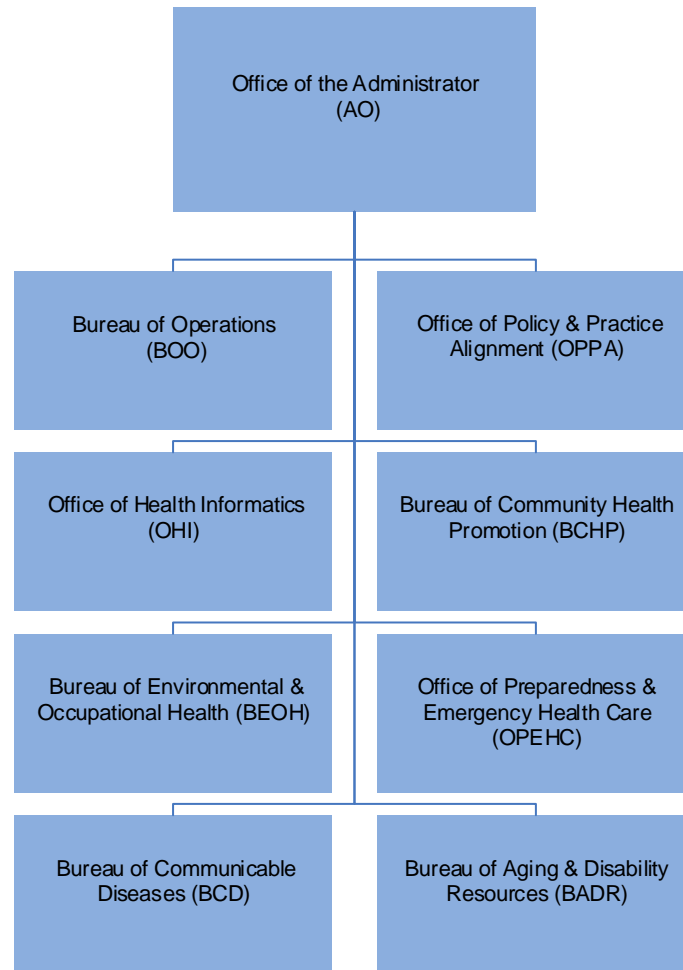

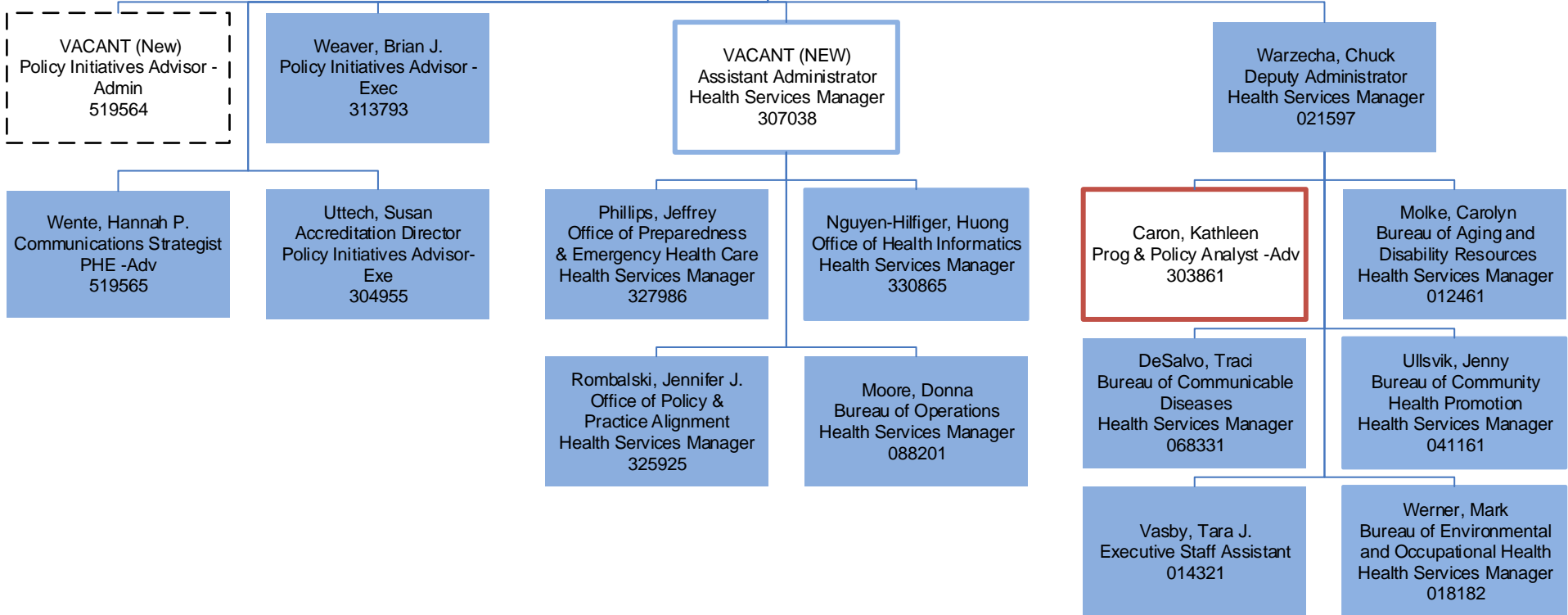

LEGEND:

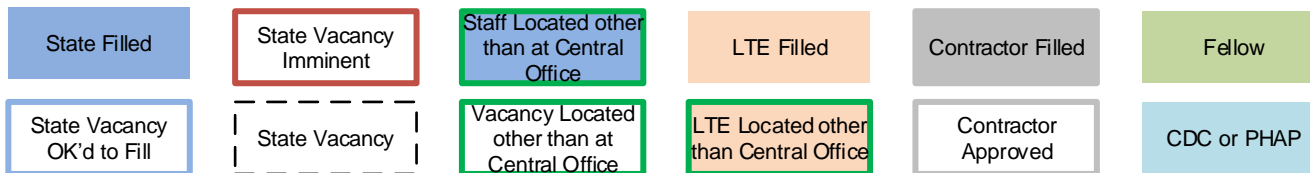

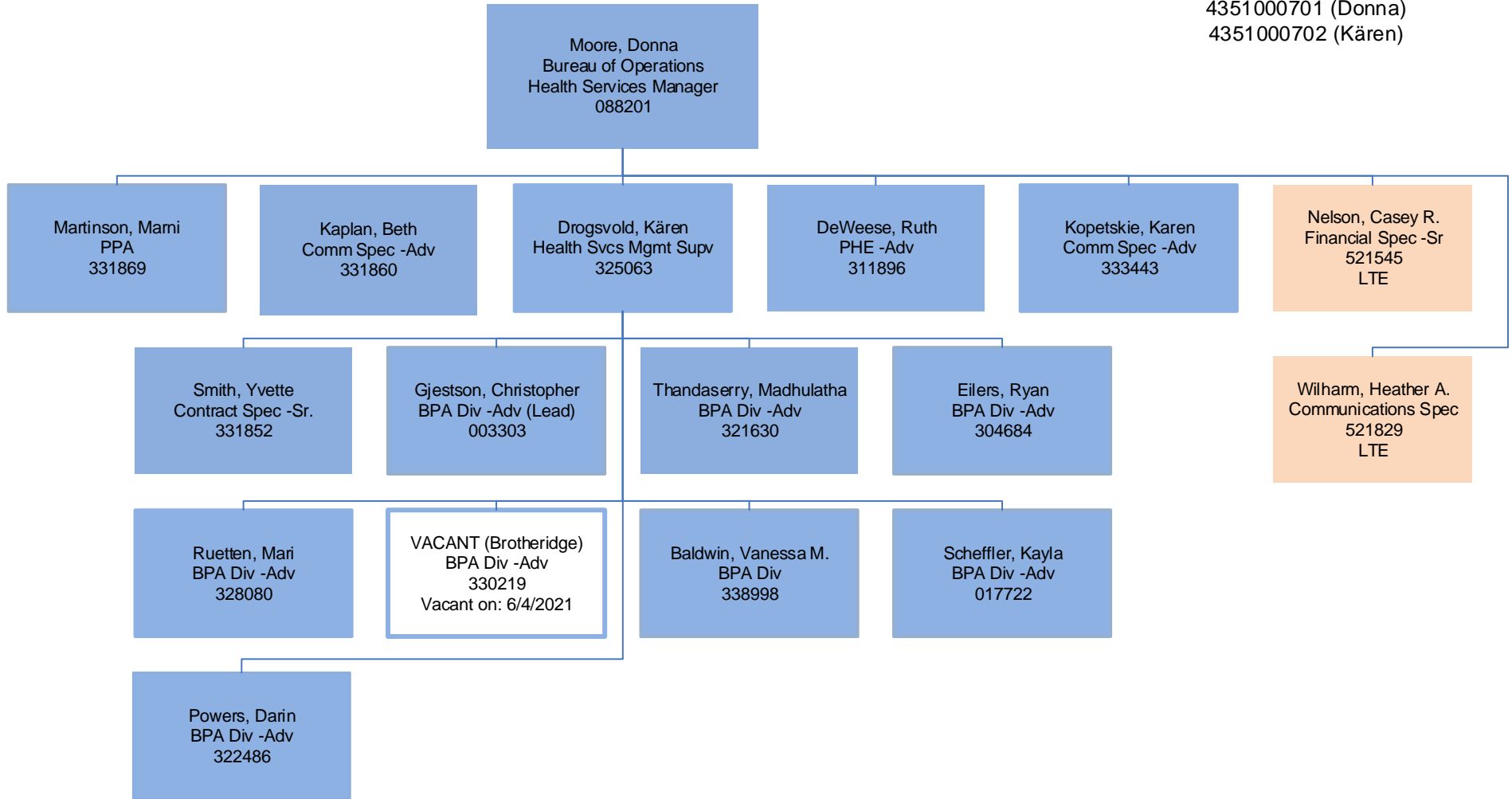

**LEGEND:**

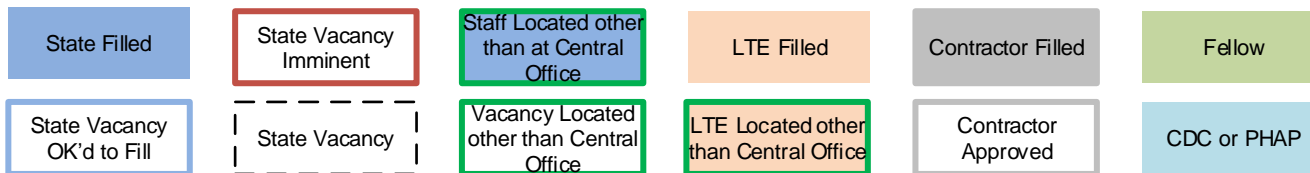

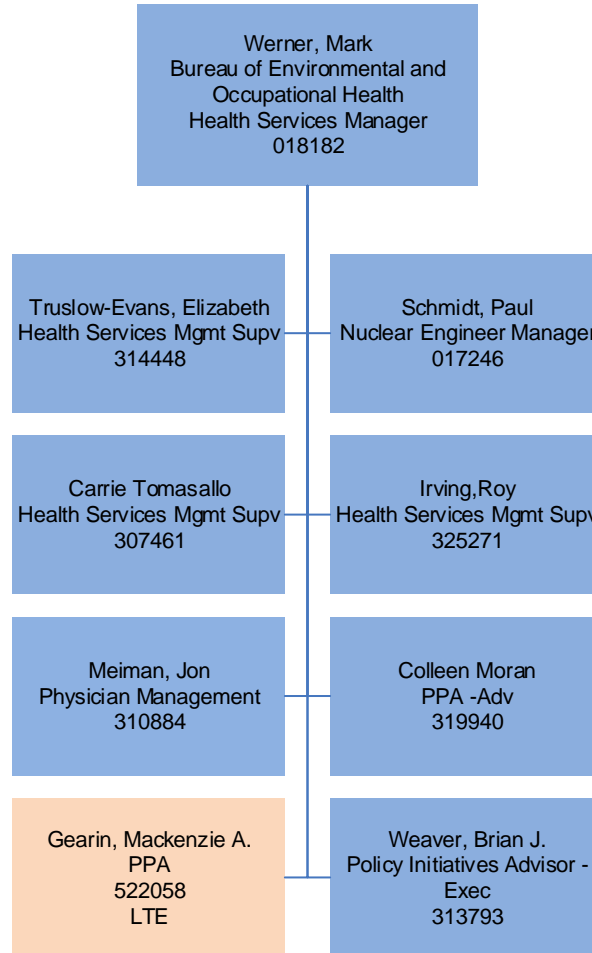

LEGEND:

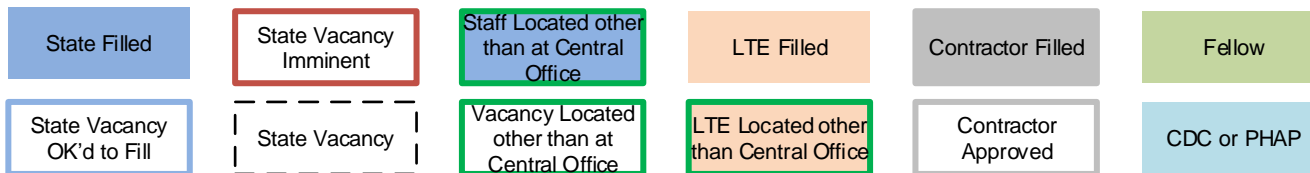

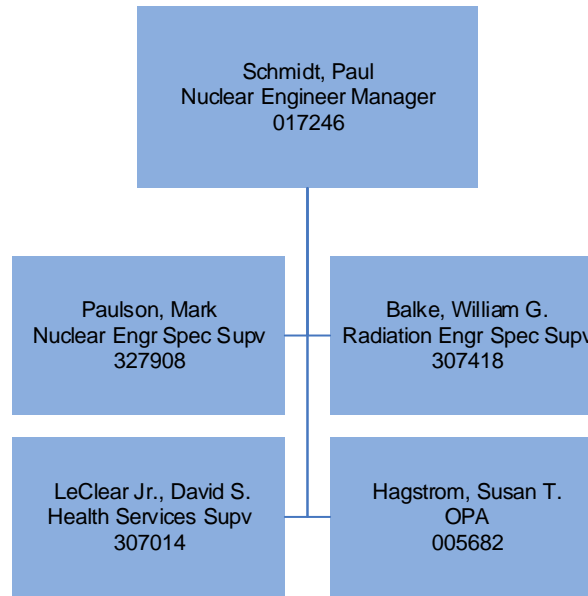

LEGEND:

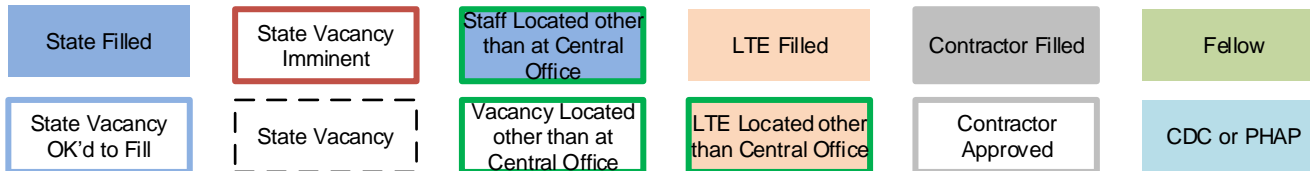

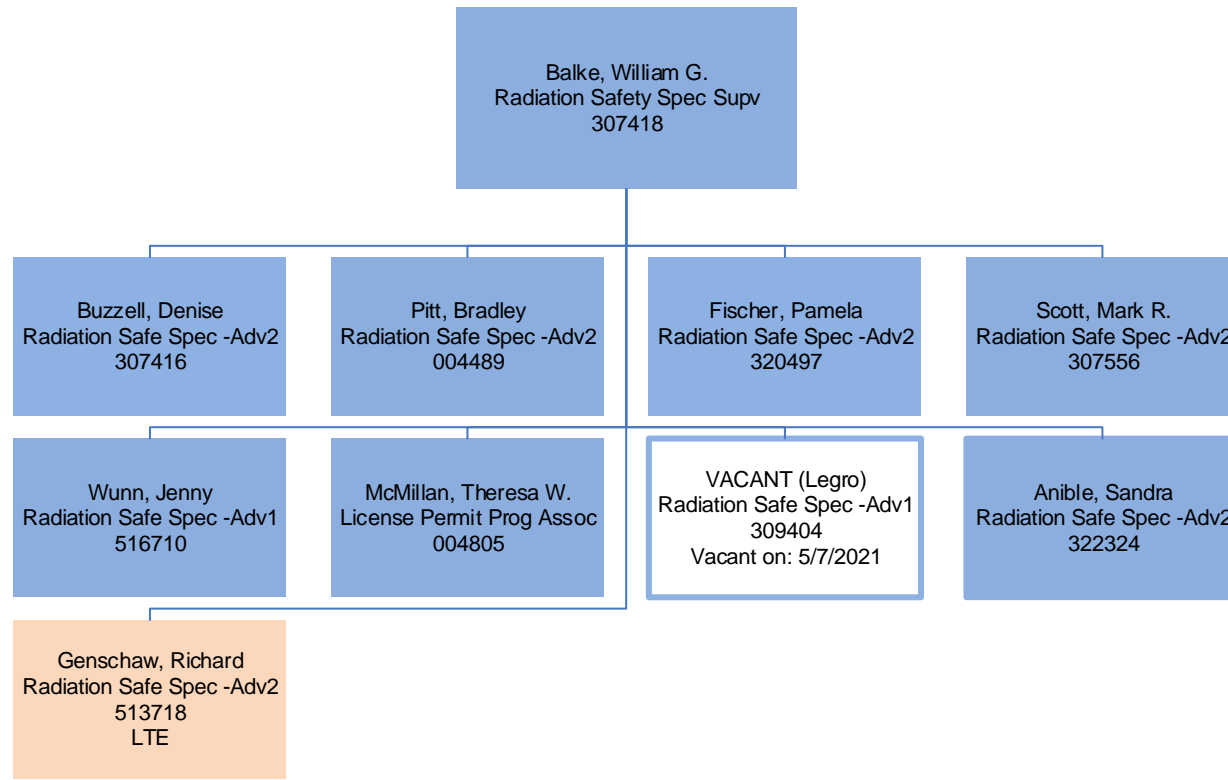

LEGEND:

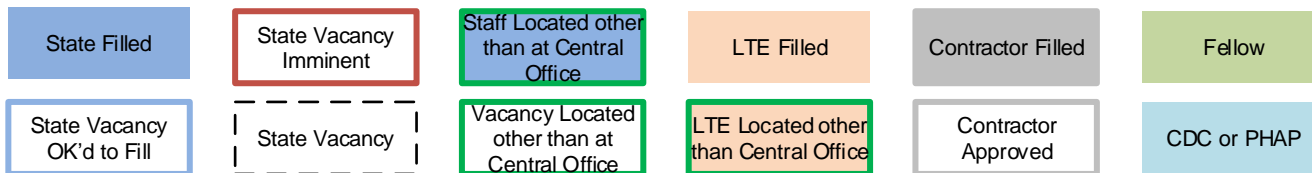



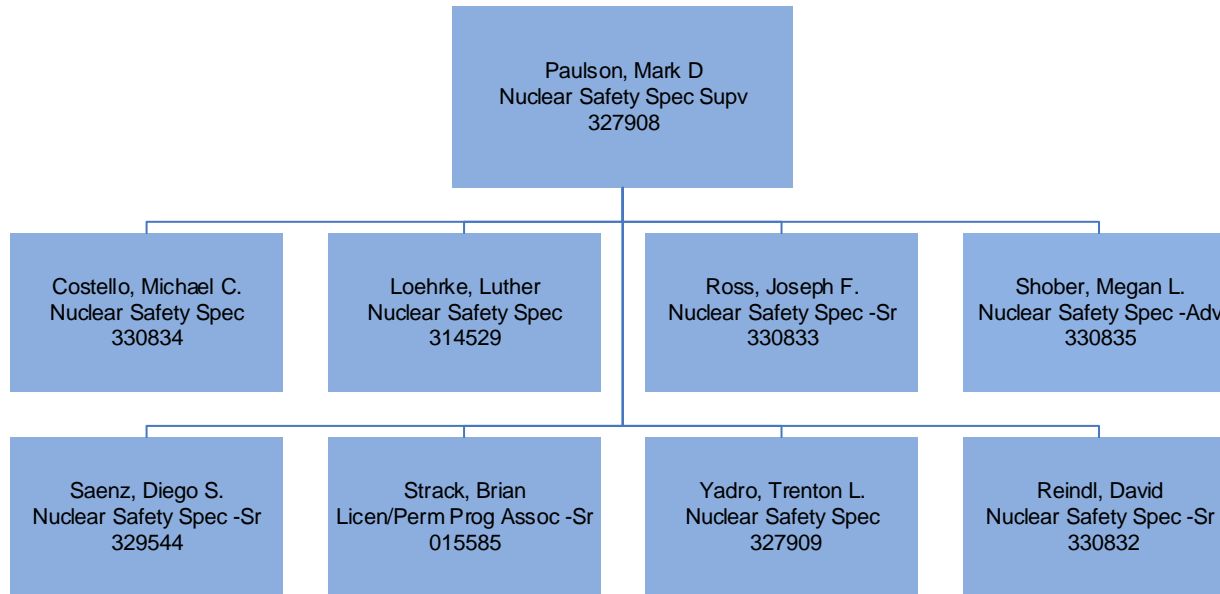

**LEGEND:**

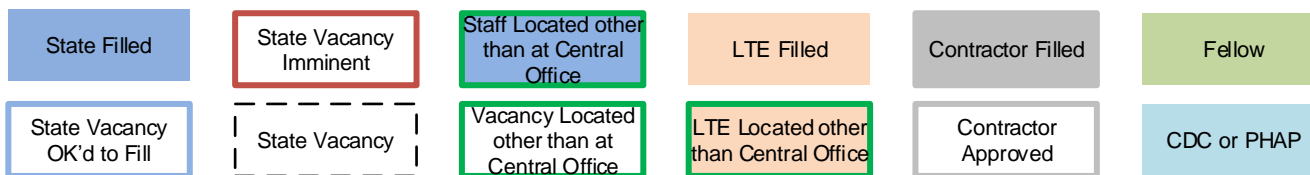

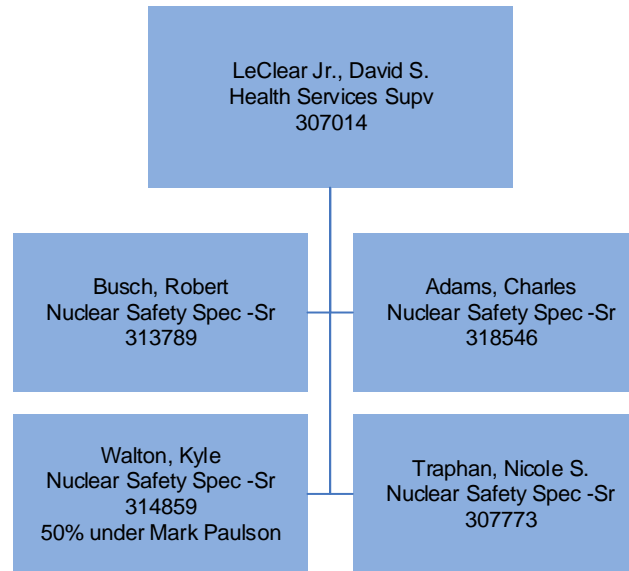

LEGEND:

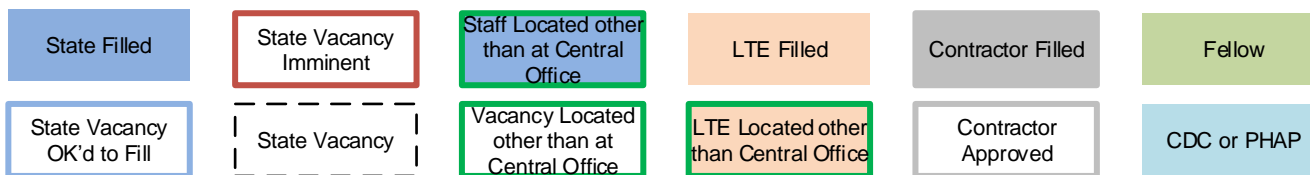

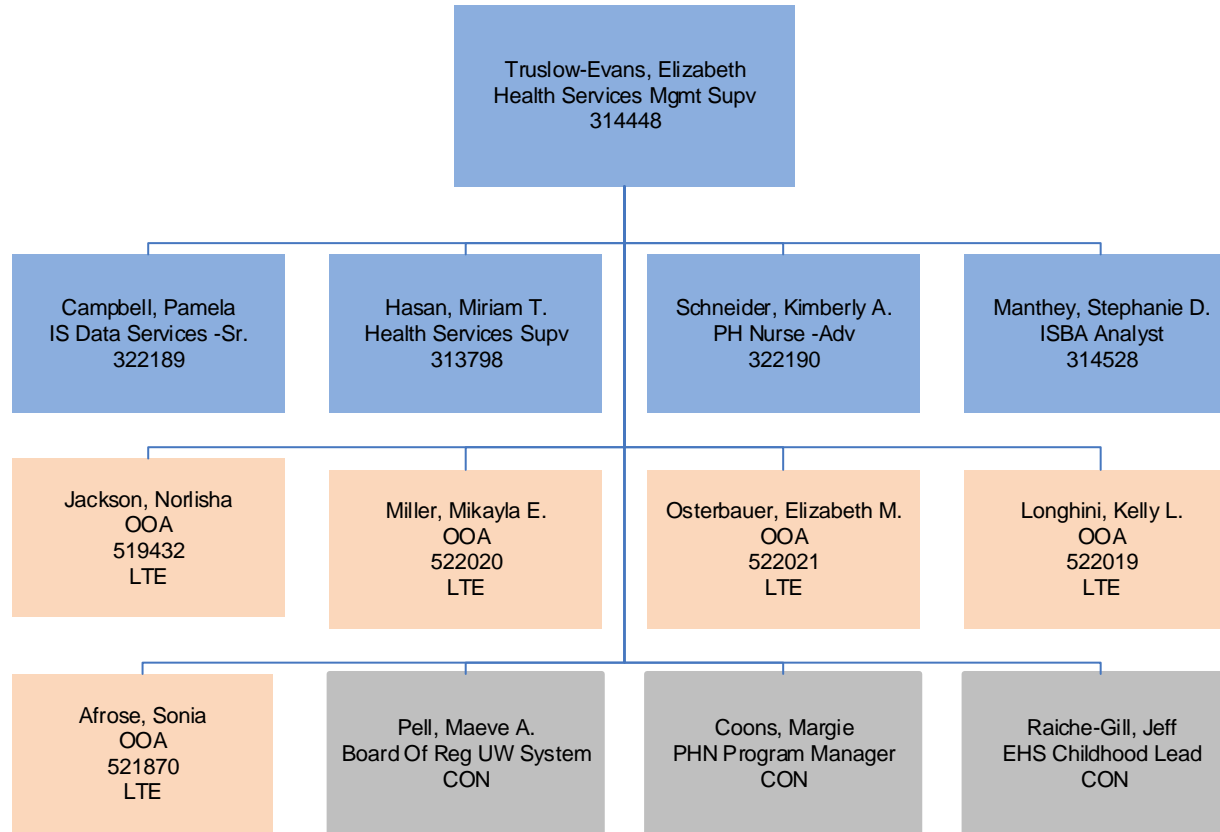

LEGEND:

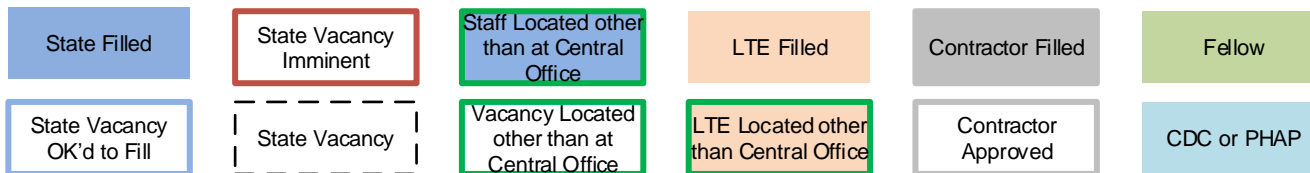

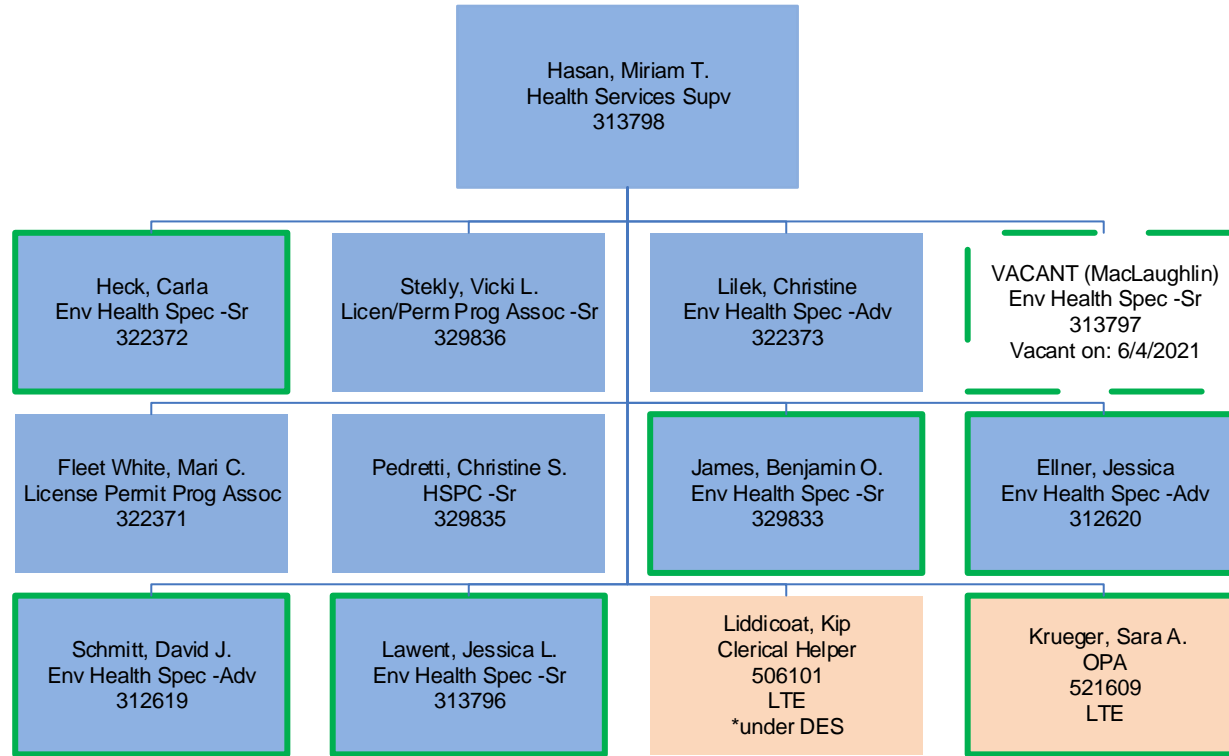

LEGEND:

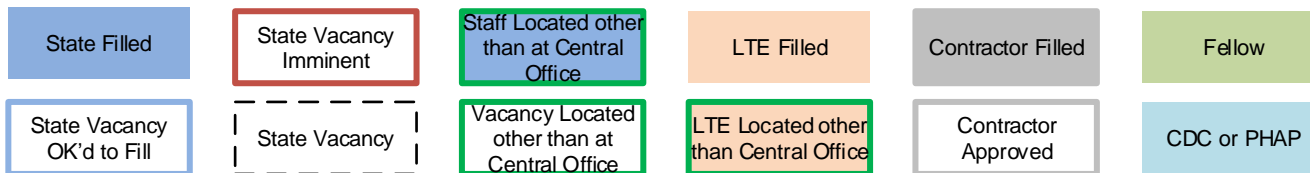

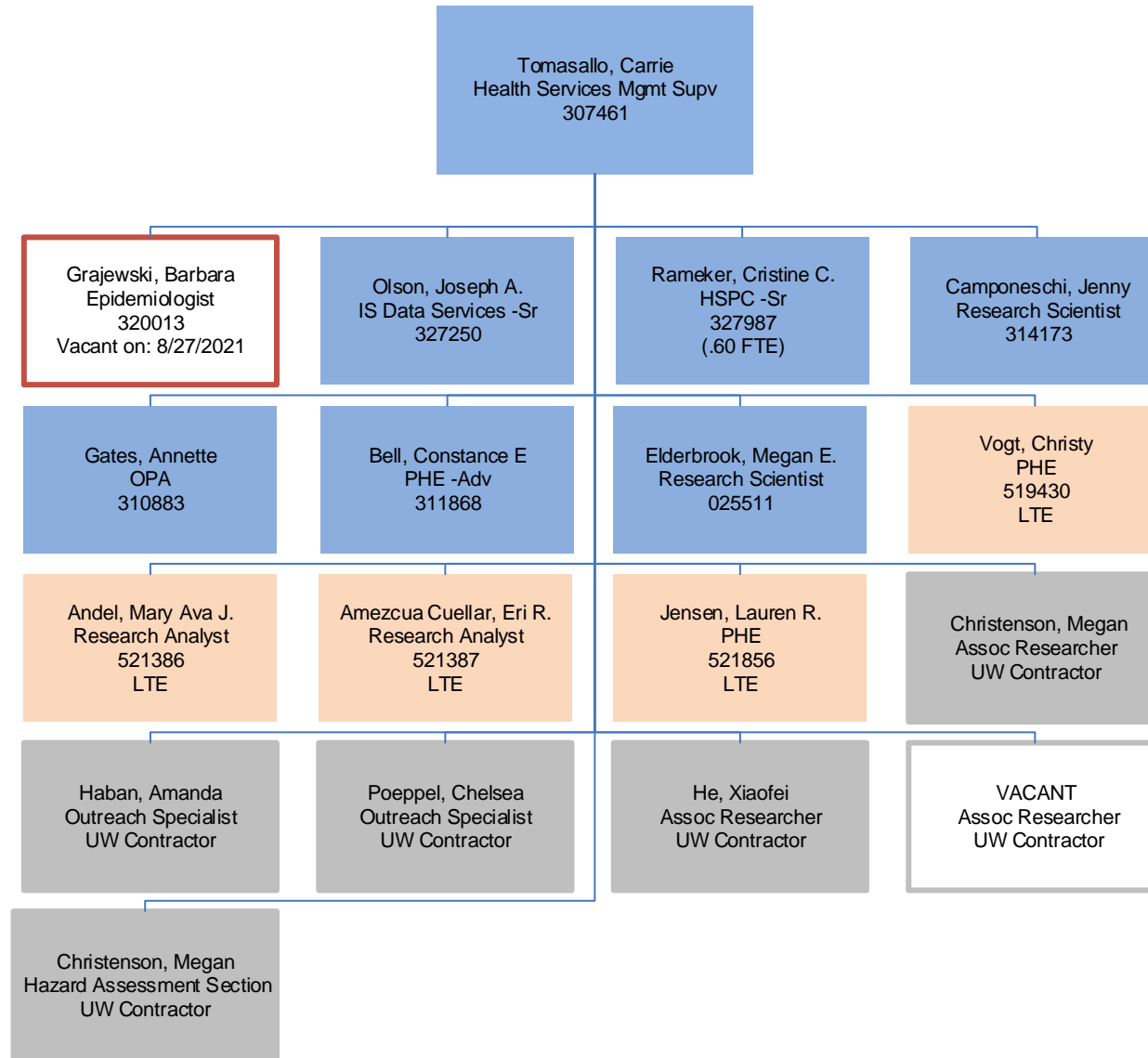

LEGEND:

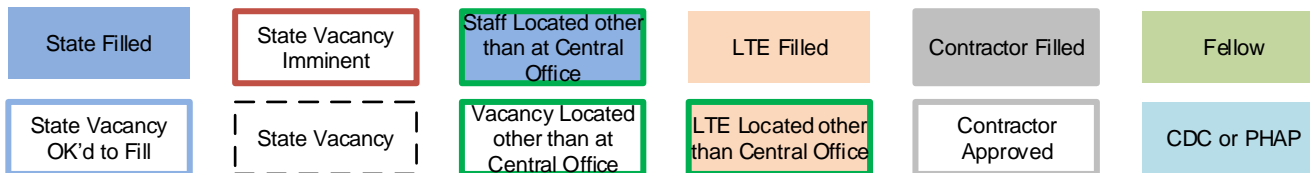

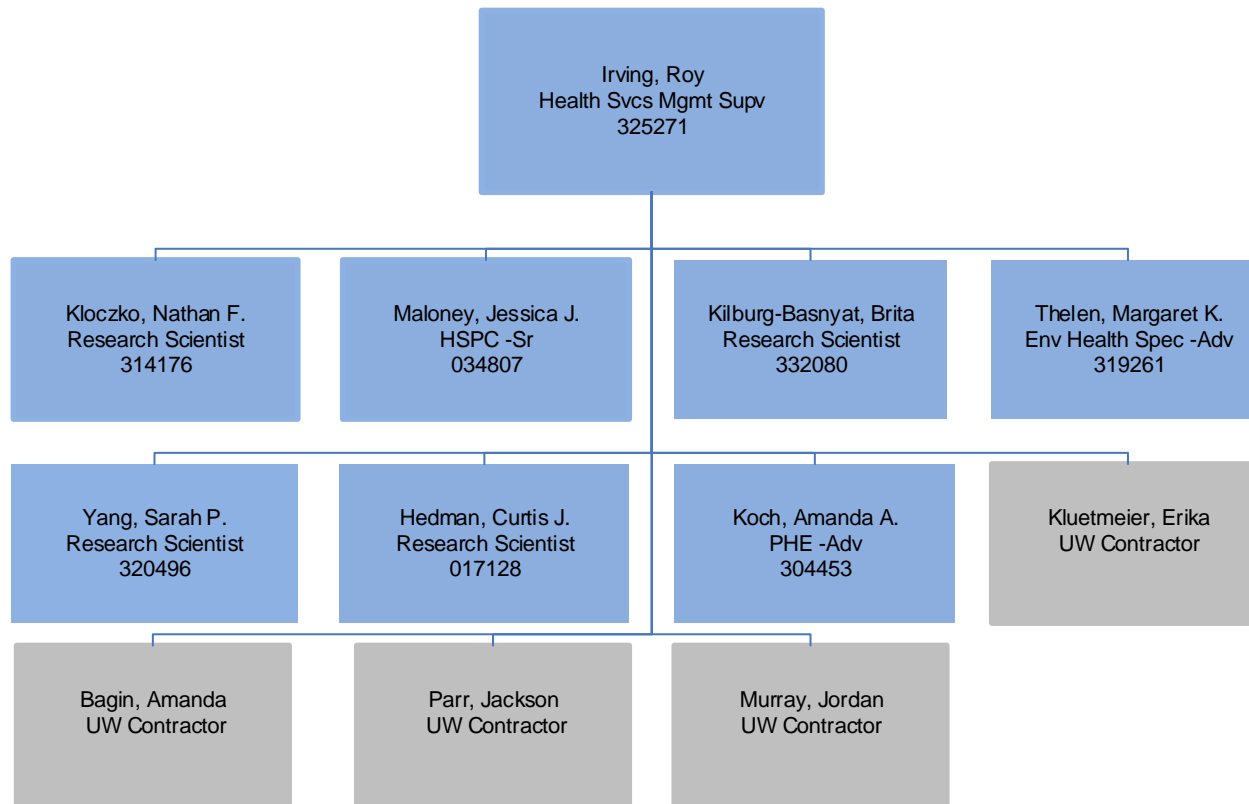

LEGEND:

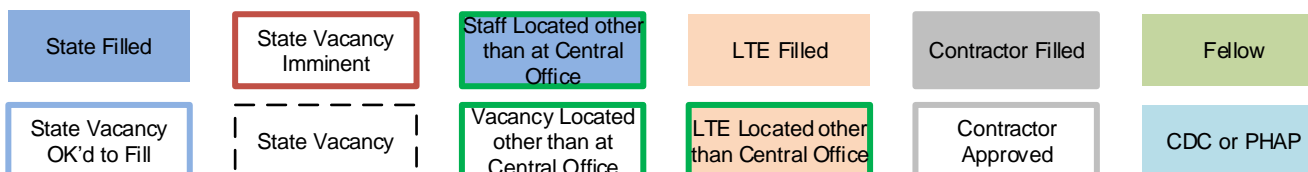

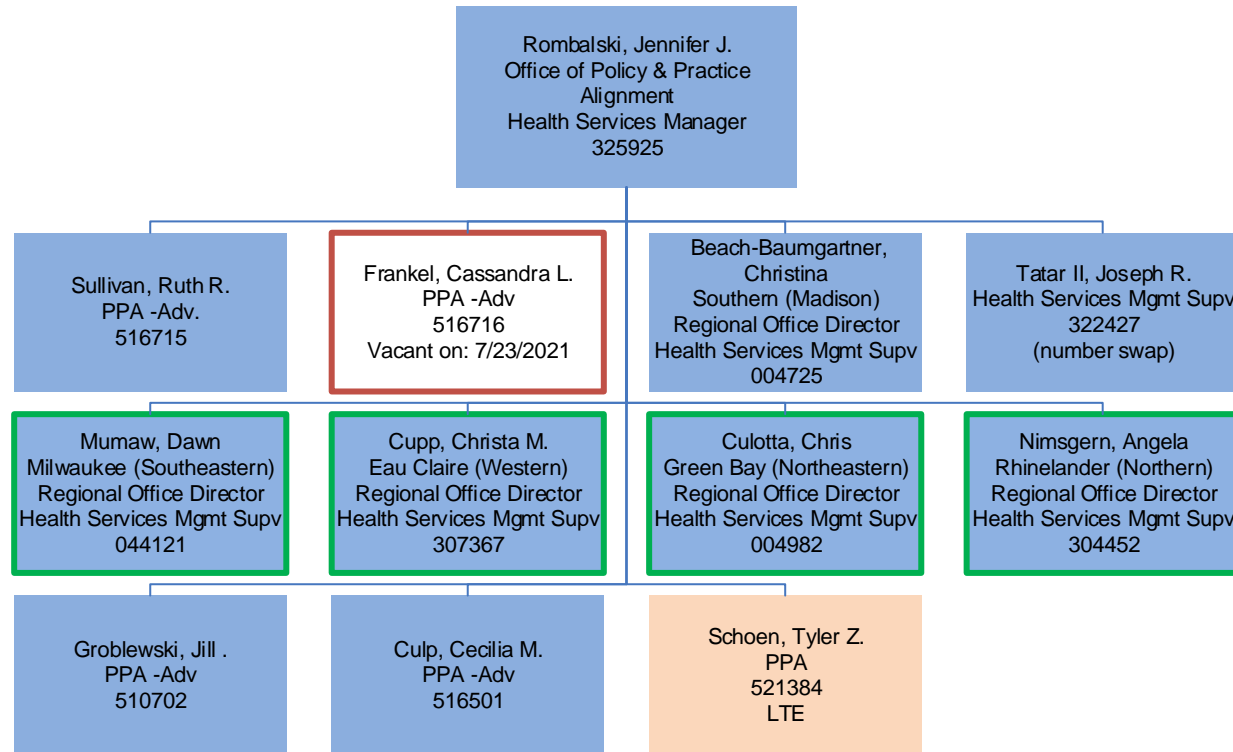

LEGEND:

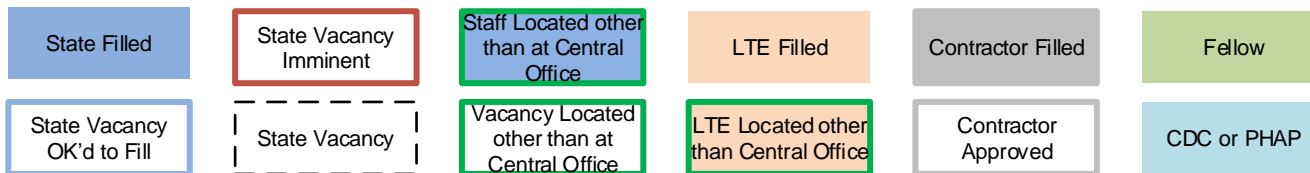

Tatar II, Joseph R.  
Health Services Mgmt Supv  
322427  
(number swap)

LEGEND:

|                            |                        |  |                                       |                     |             |
|----------------------------|------------------------|--|---------------------------------------|---------------------|-------------|
| State Filled               | State Vacancy Imminent | Staff Located other than at Central Office   | LTE Filled                            | Contractor Filled   | Fellow      |
| State Vacancy OK'd to Fill | State Vacancy          | Vacancy Located other than at Central Office | LTE Located other than Central Office | Contractor Approved | CDC or PHAP |



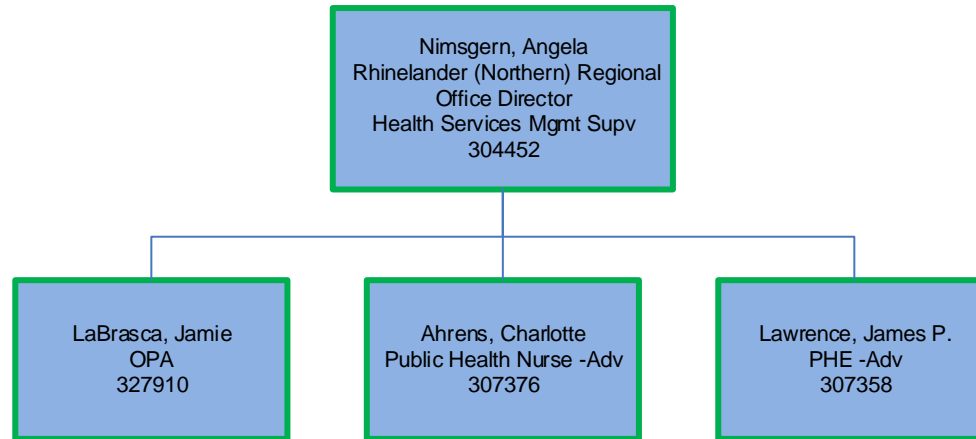

LEGEND:

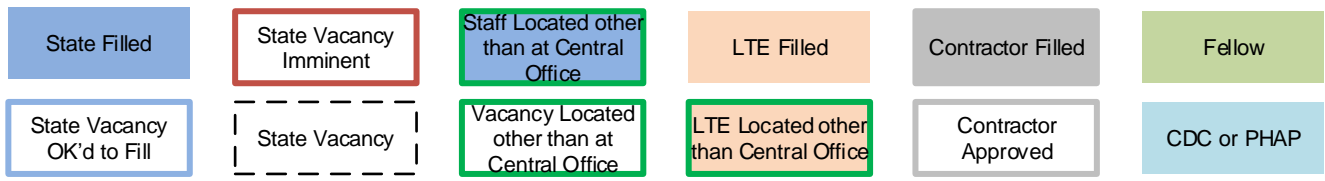

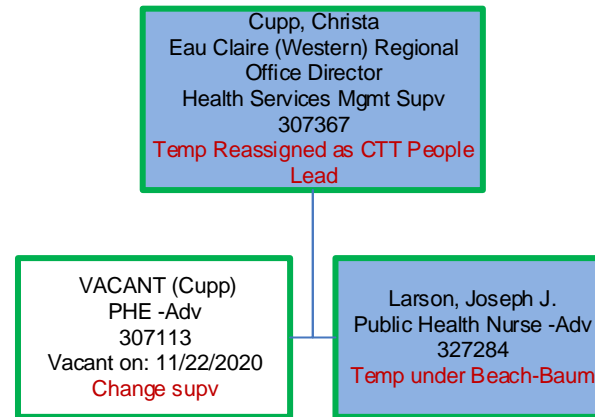

LEGEND:

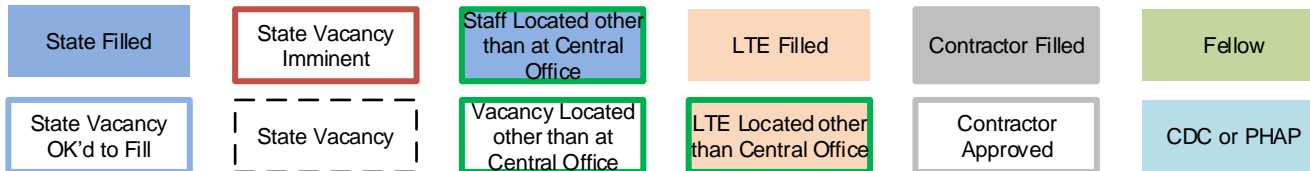

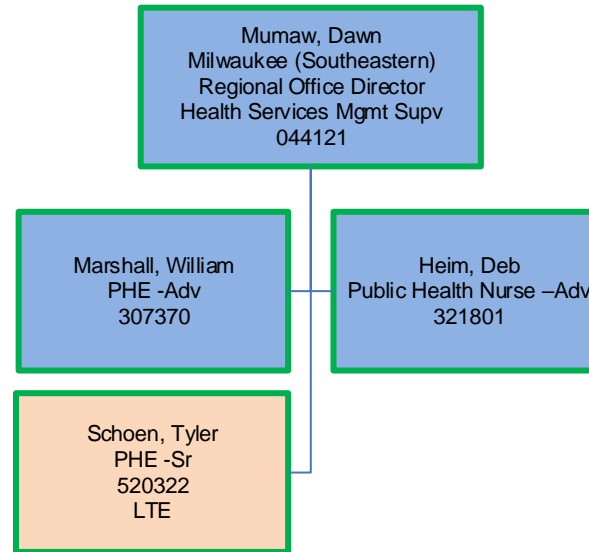

LEGEND:

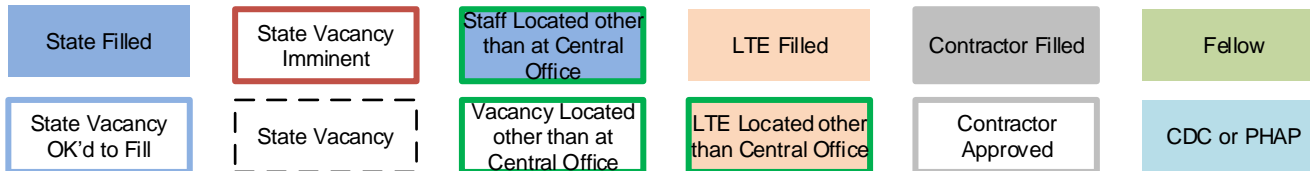

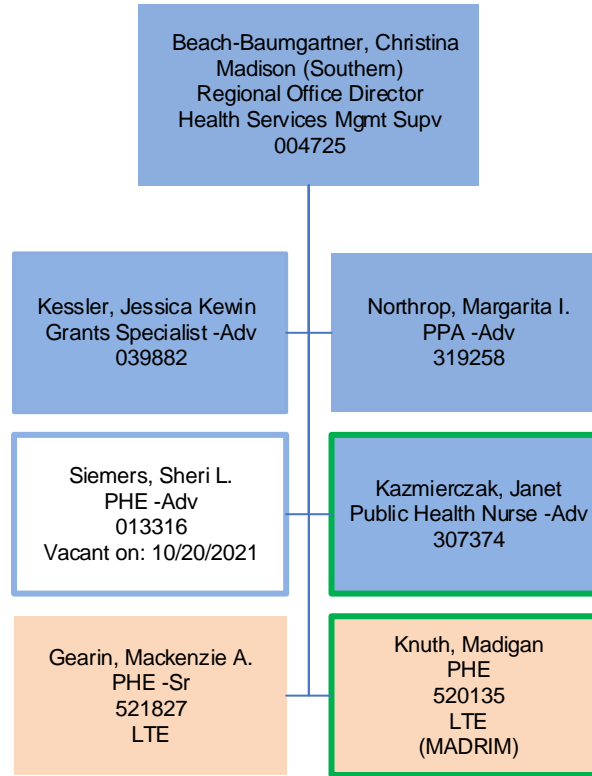

LEGEND:

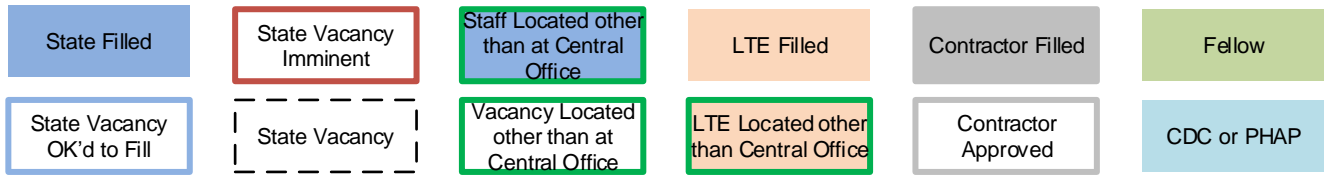

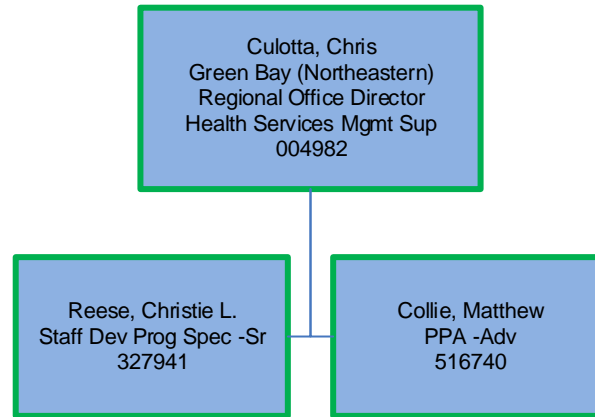

LEGEND:

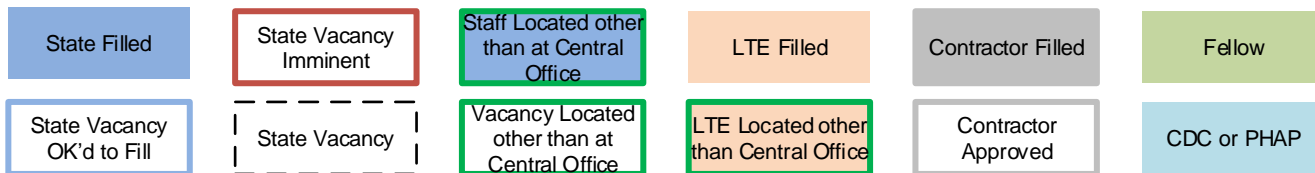

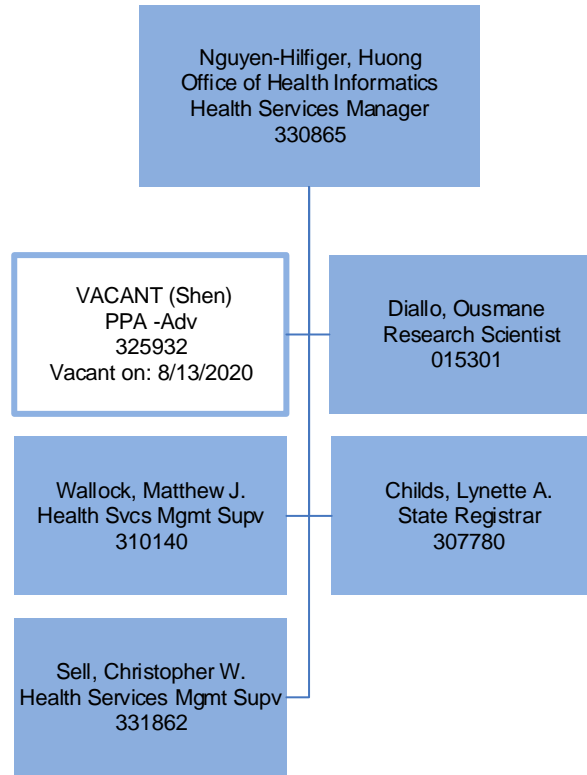

LEGEND:

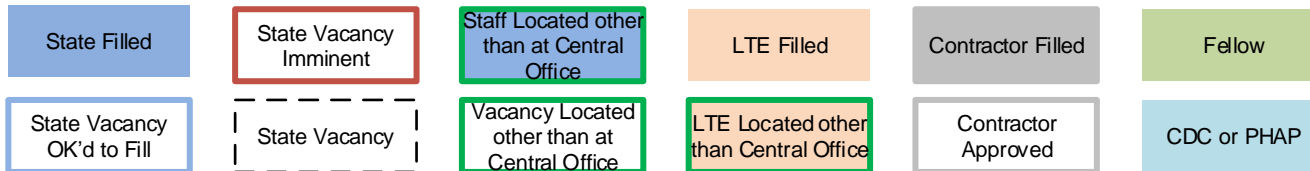

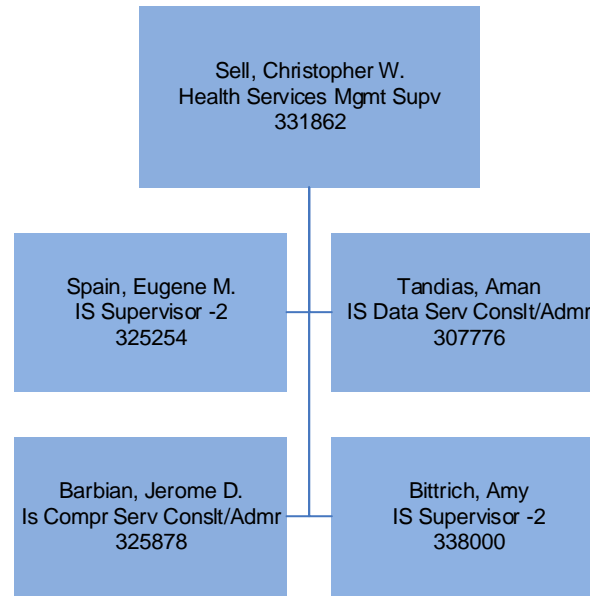

LEGEND:

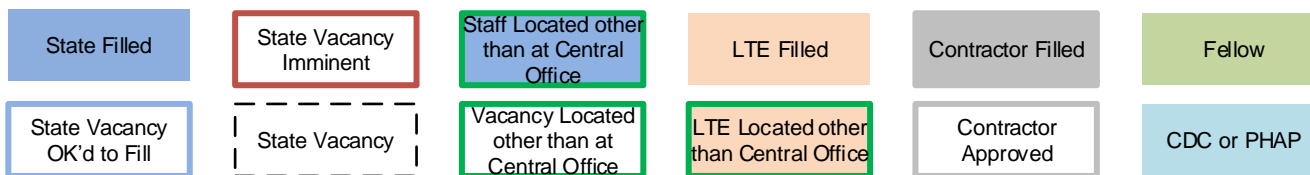

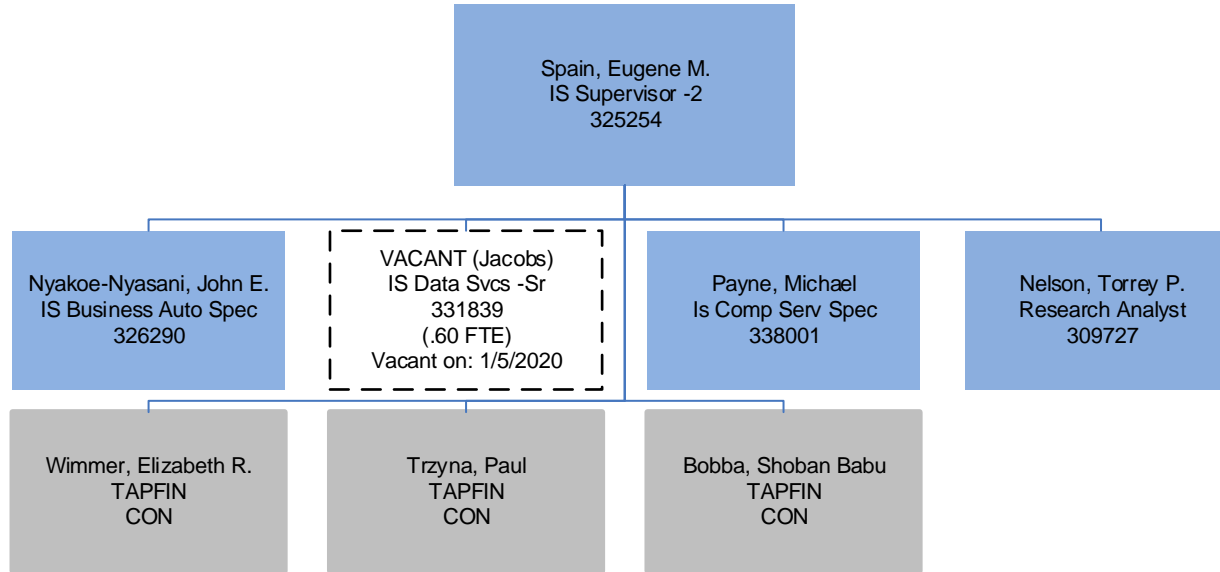

LEGEND:

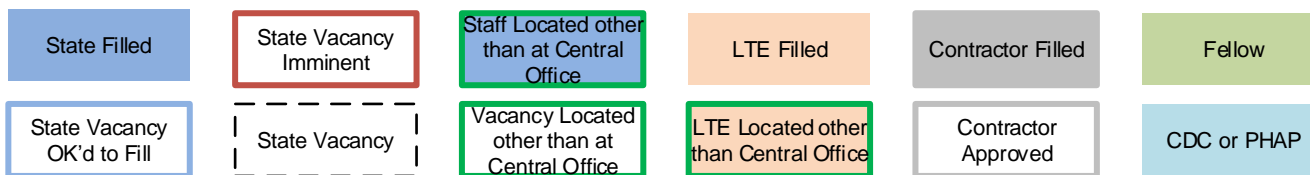



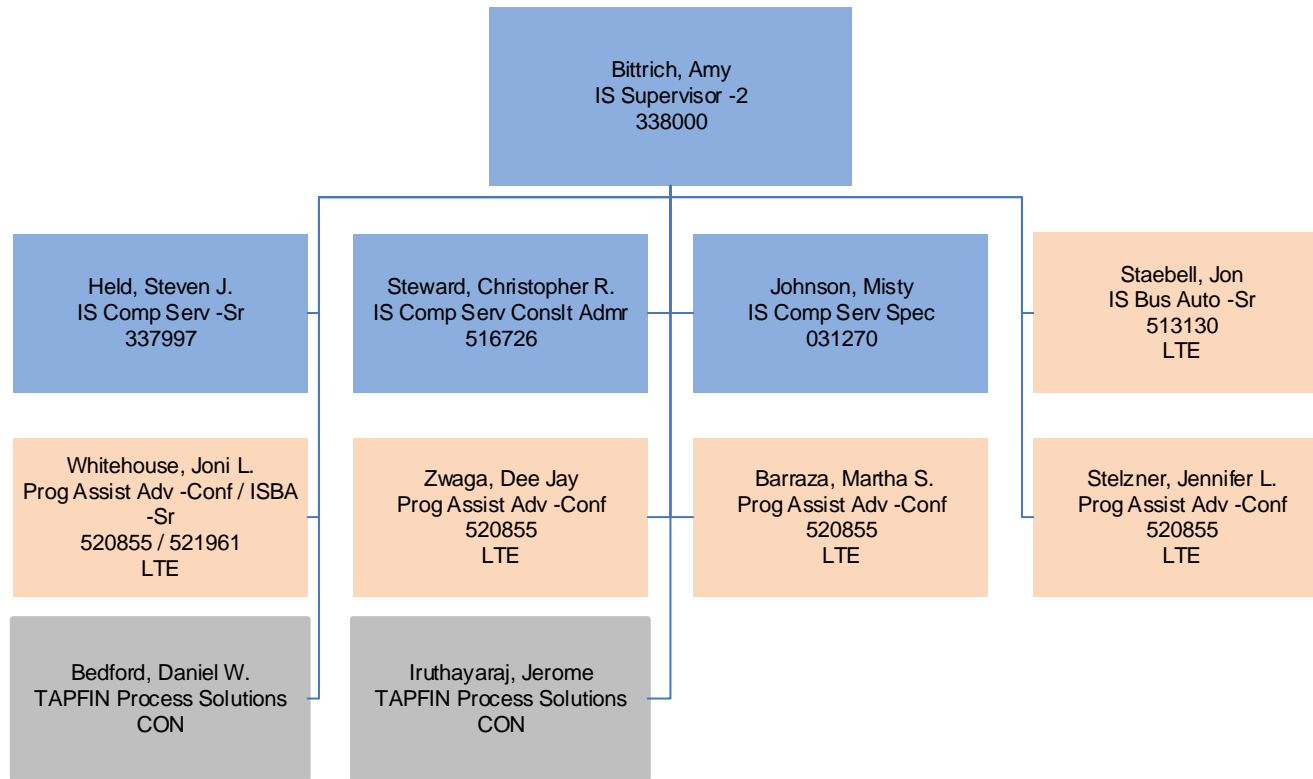

LEGEND:

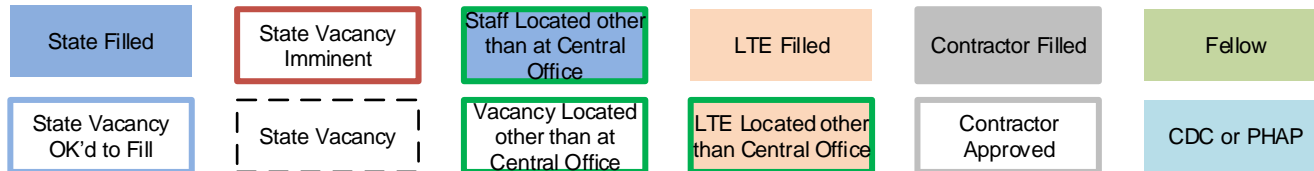

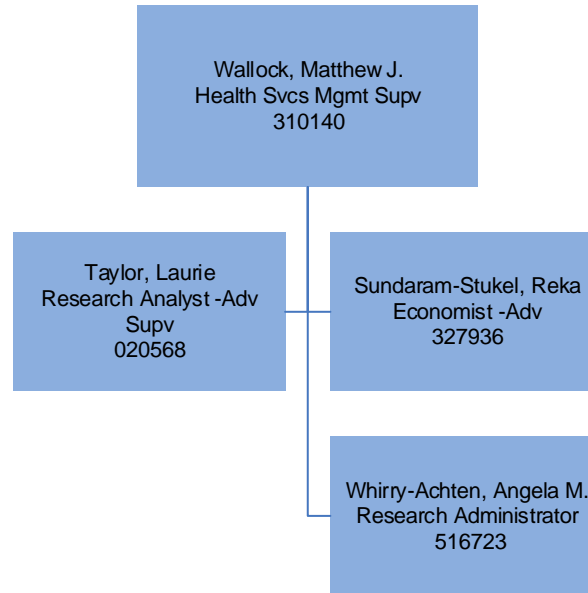

LEGEND:

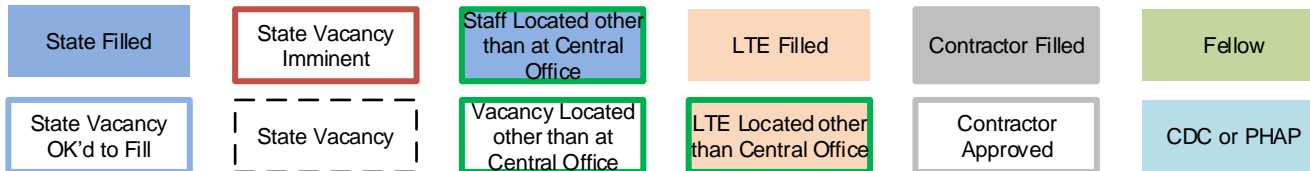

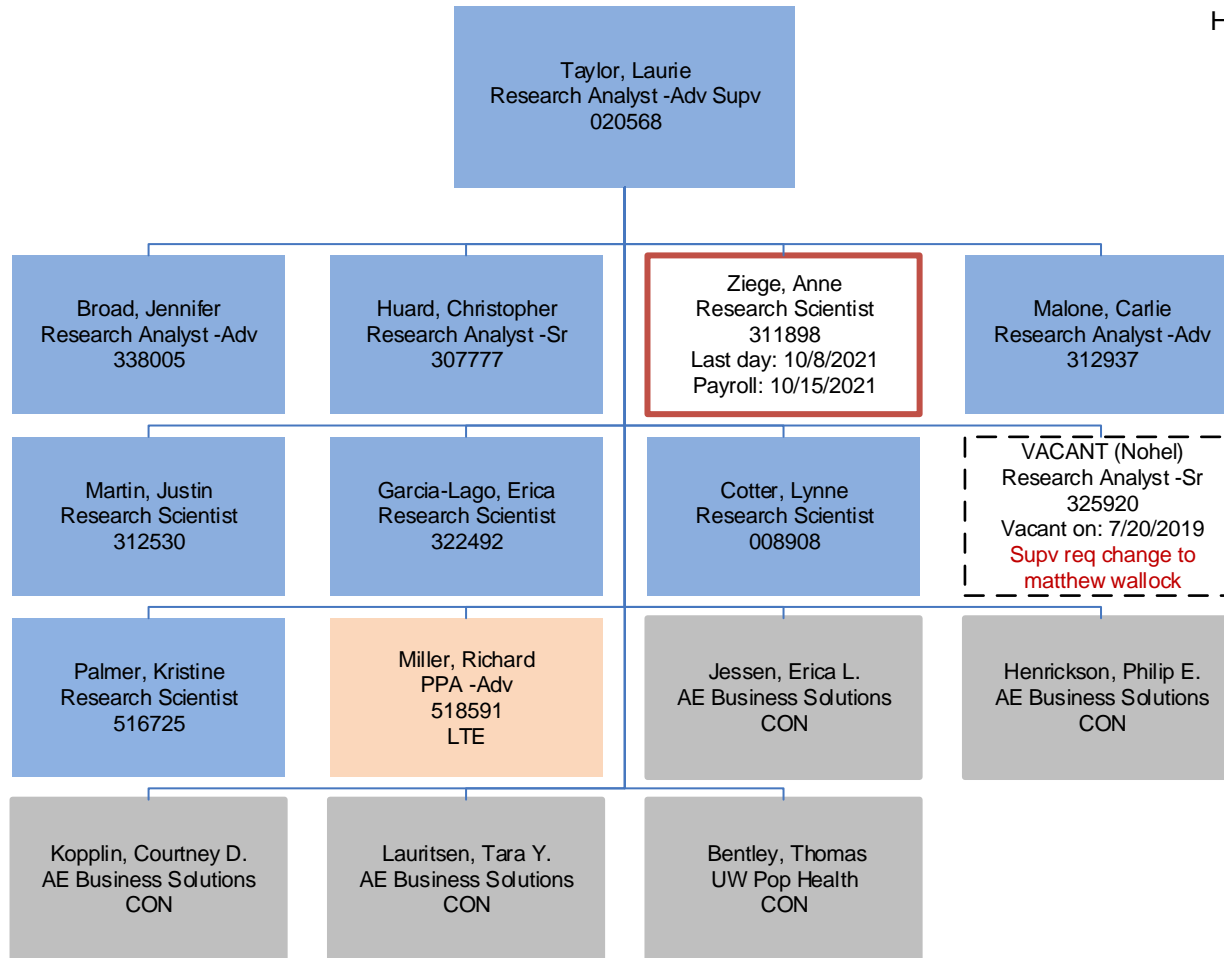

LEGEND:

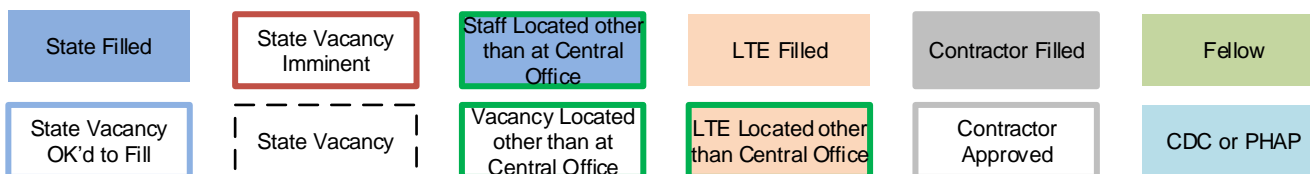

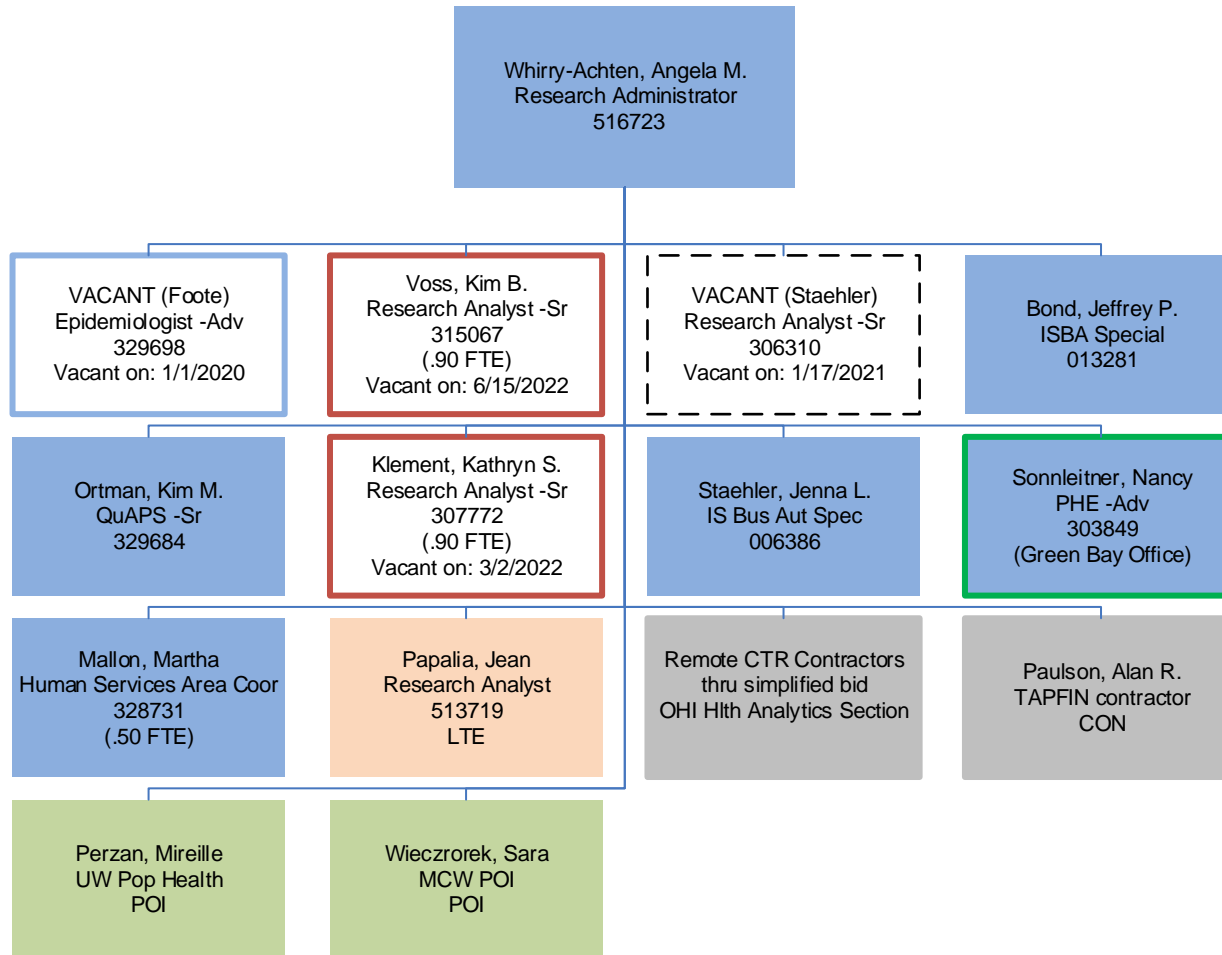

LEGEND:

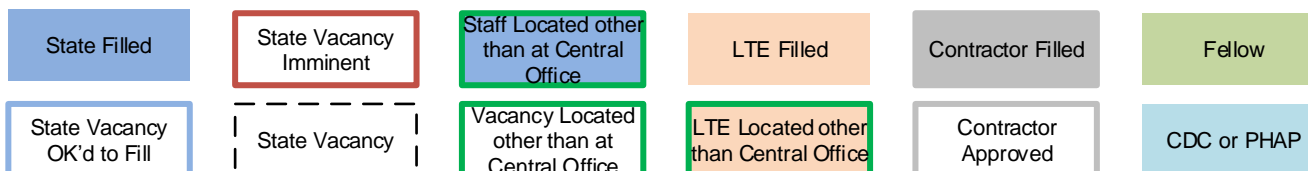

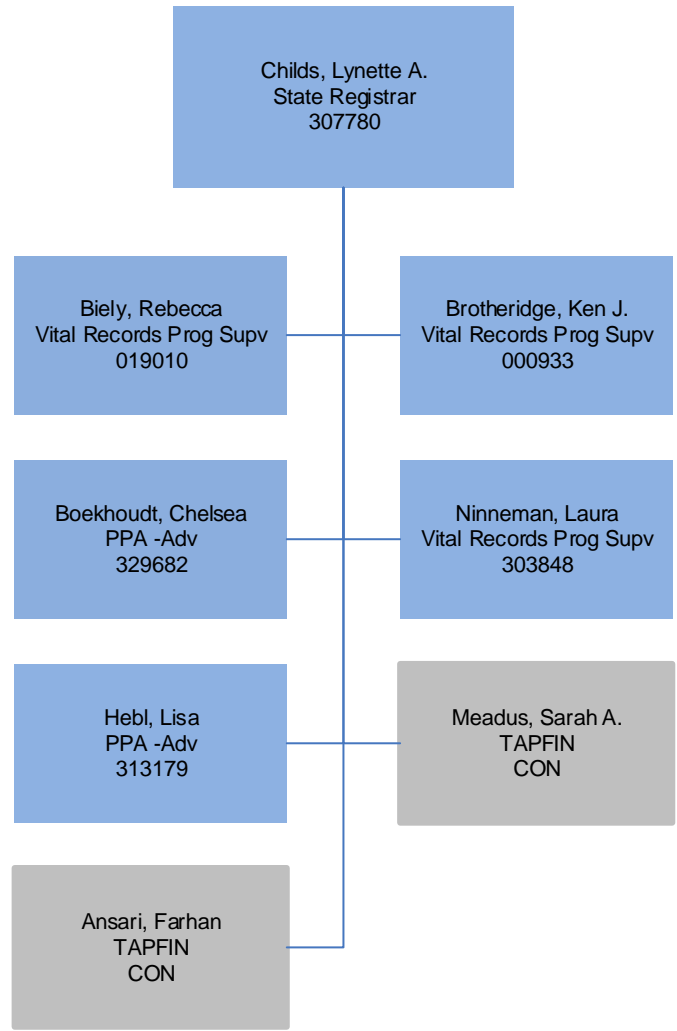

**LEGEND:**

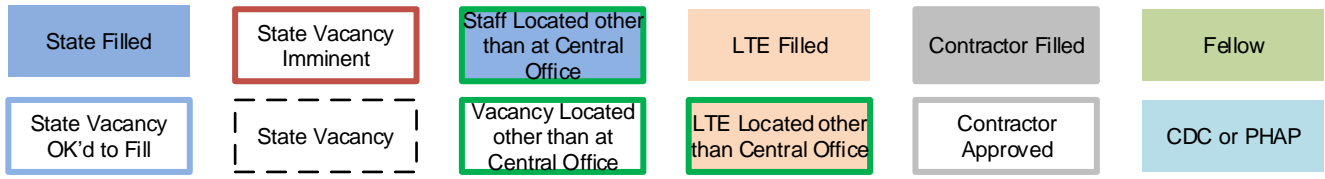

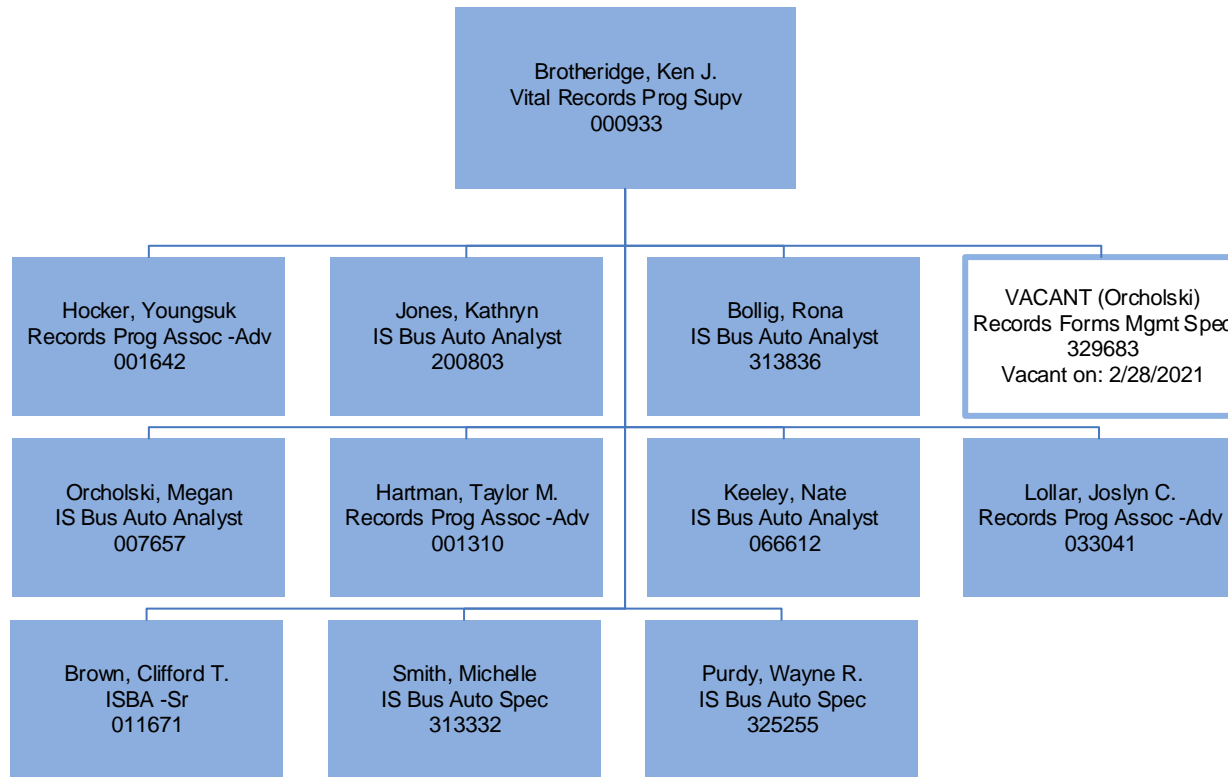

LEGEND:

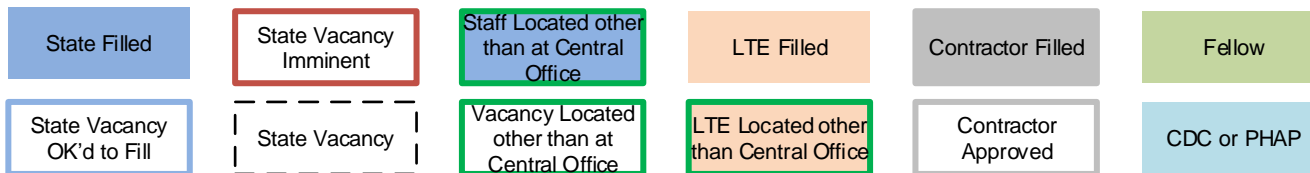

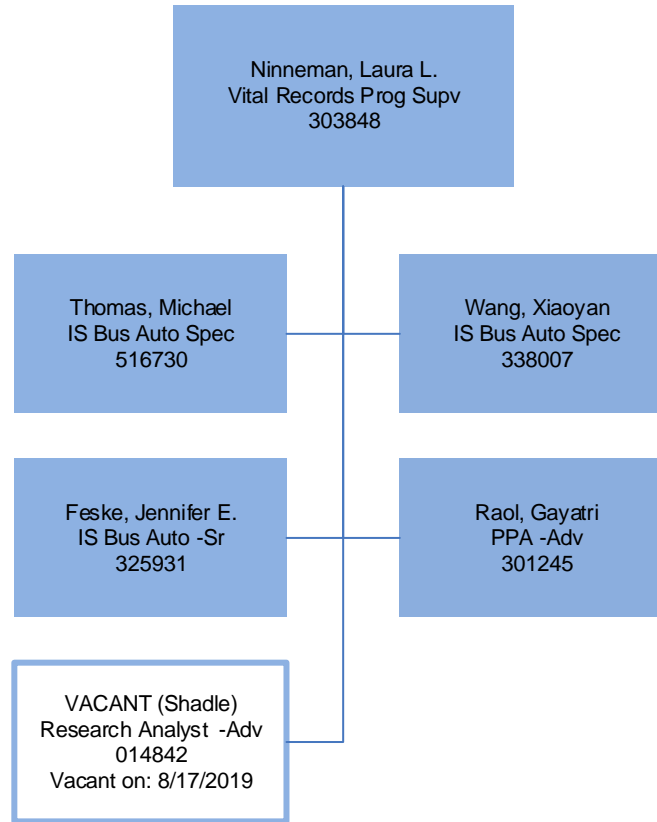

LEGEND:

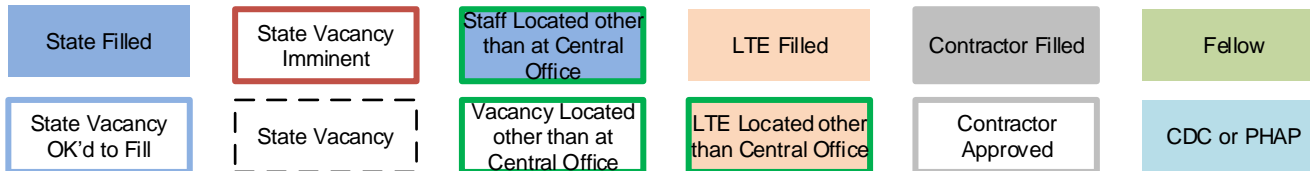

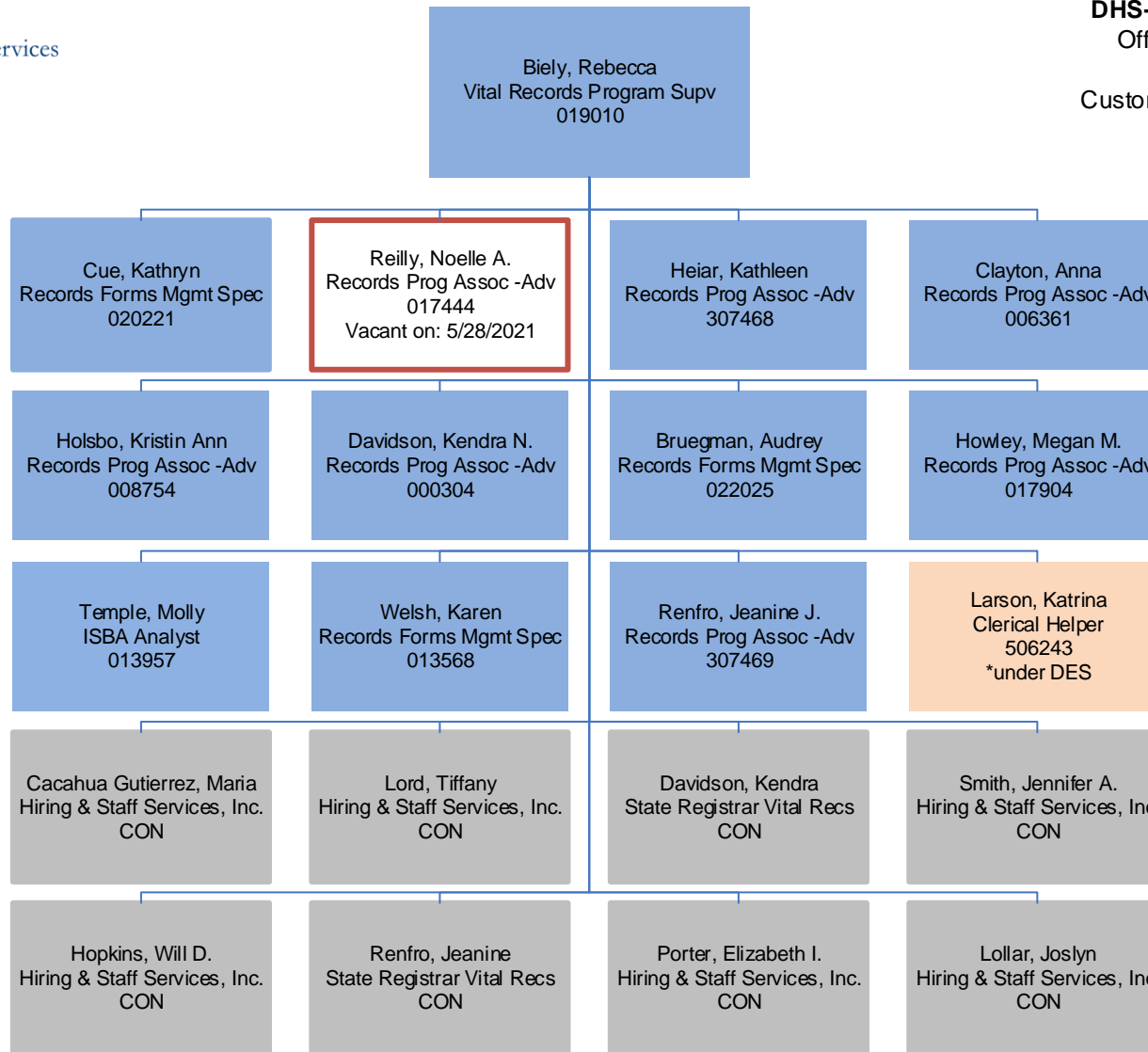

LEGEND:

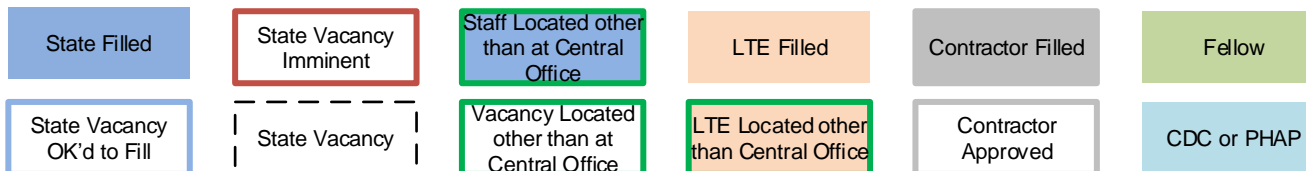



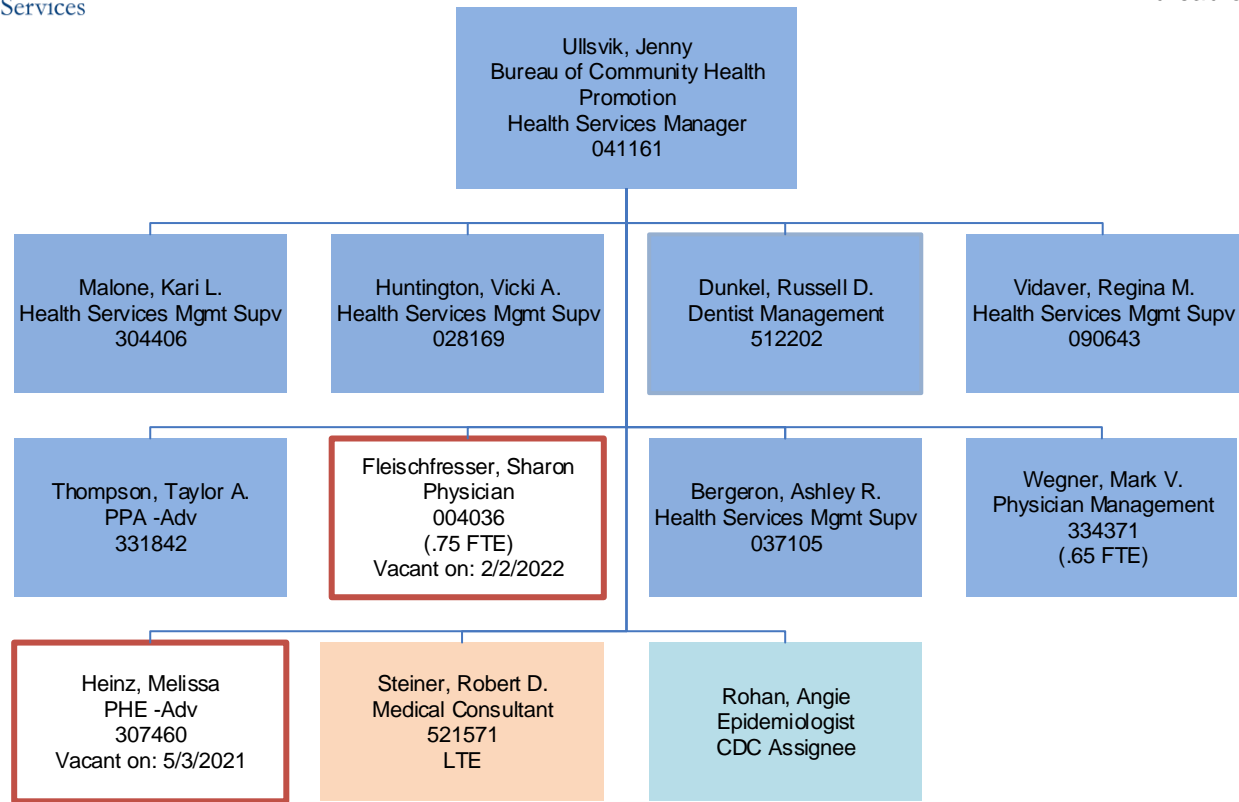

LEGEND:

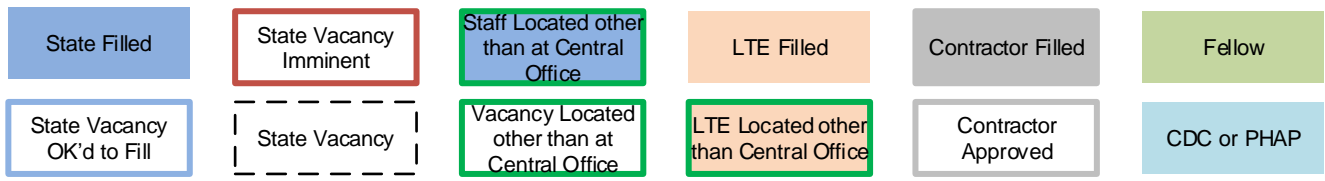

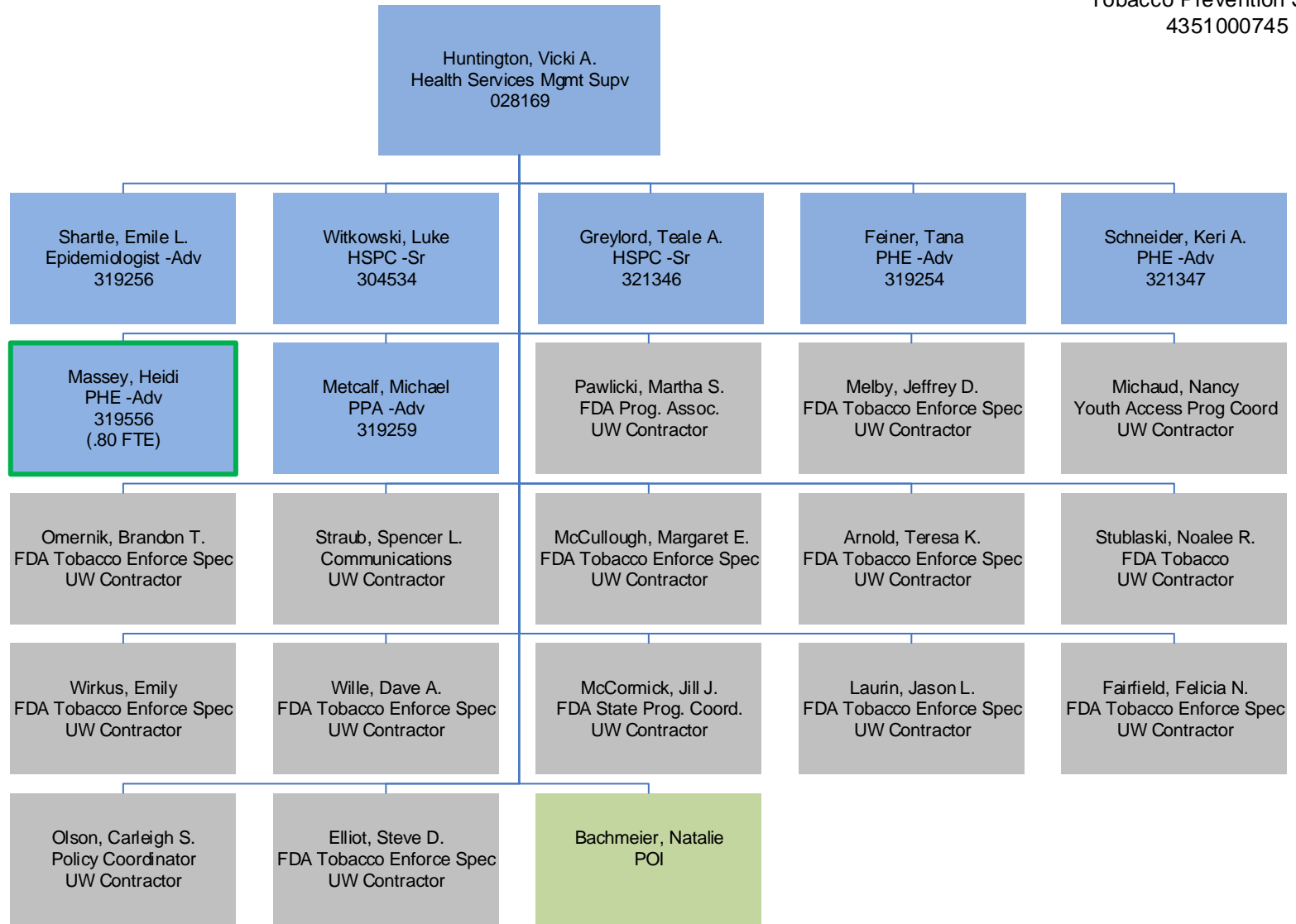

LEGEND:

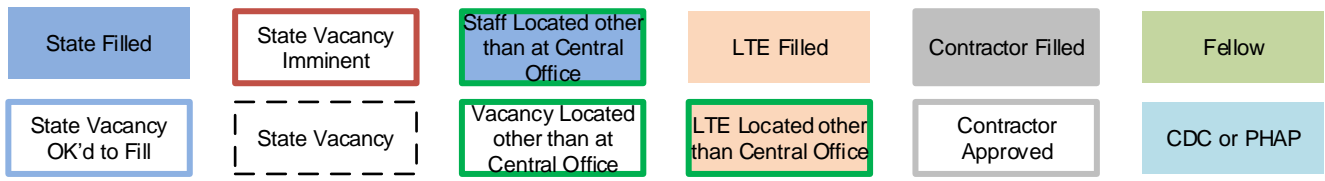

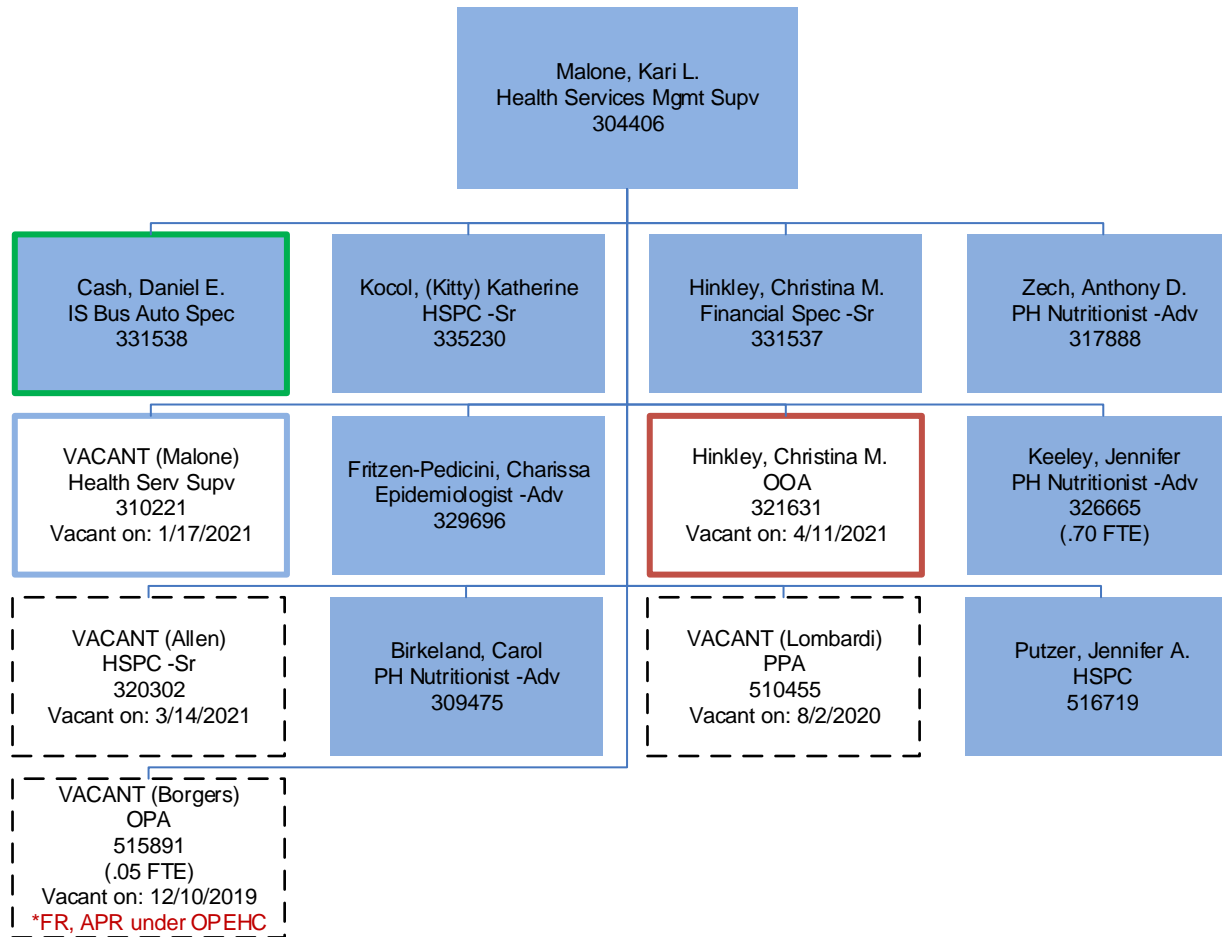

LEGEND:

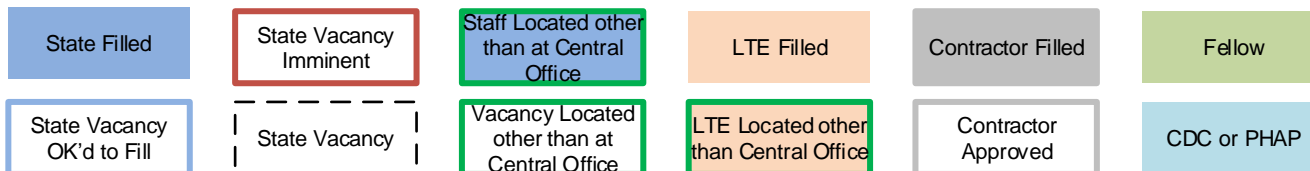

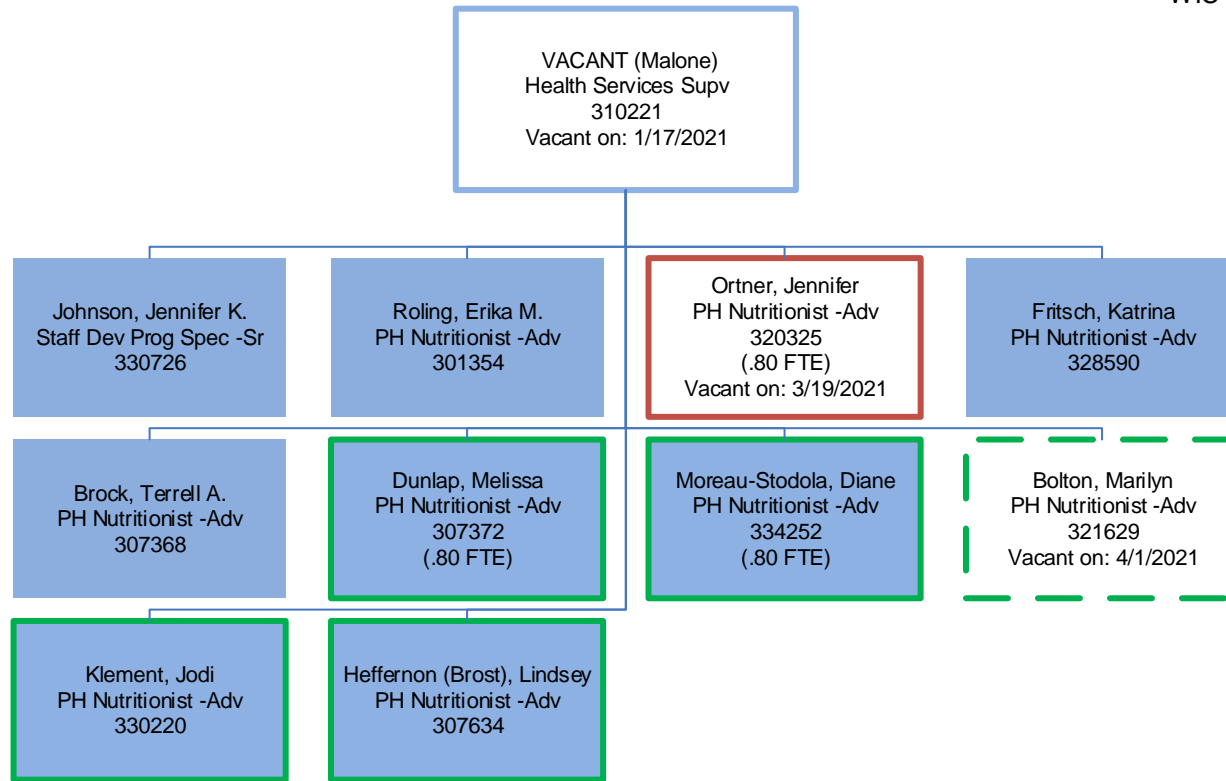

LEGEND:

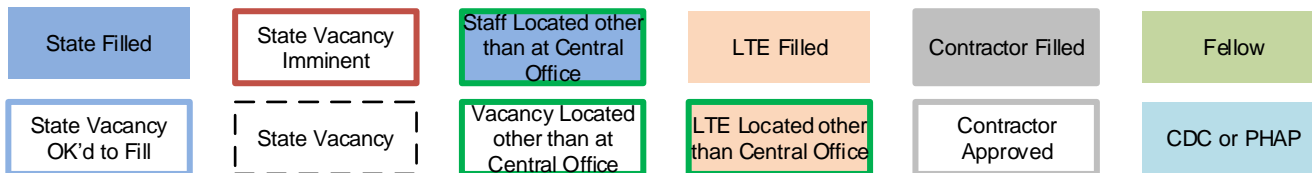

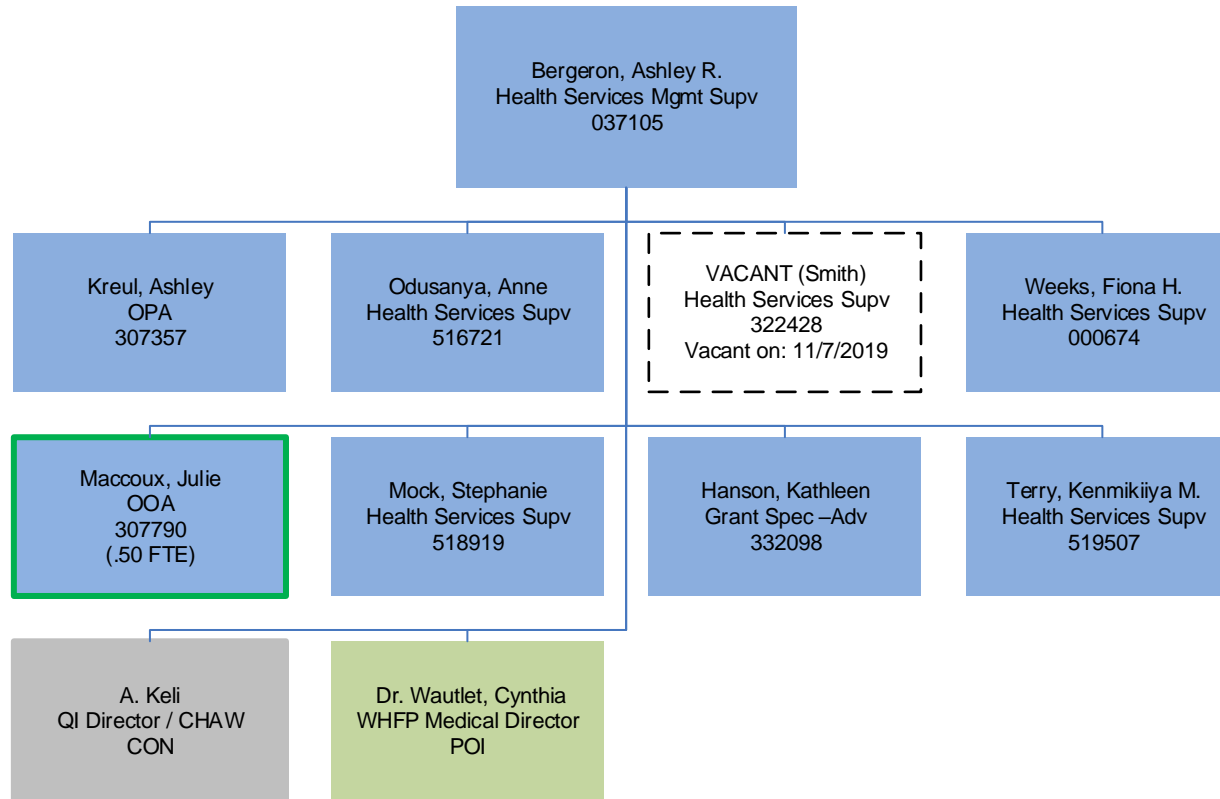

LEGEND:

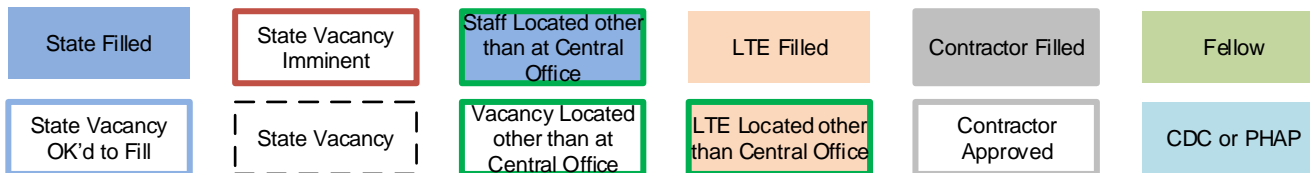

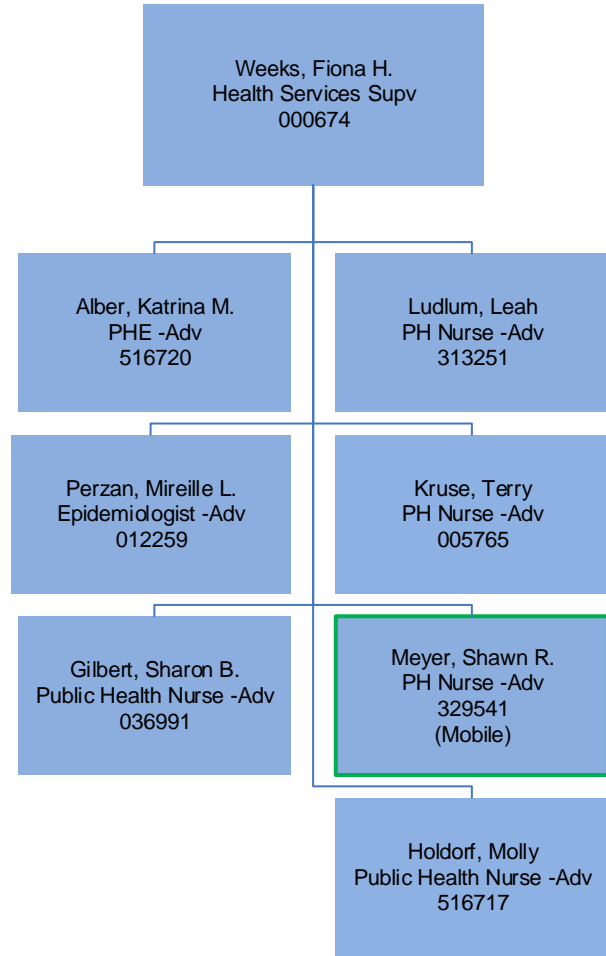

LEGEND:

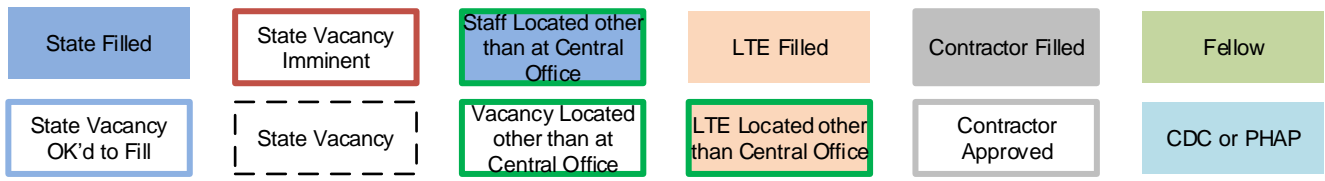

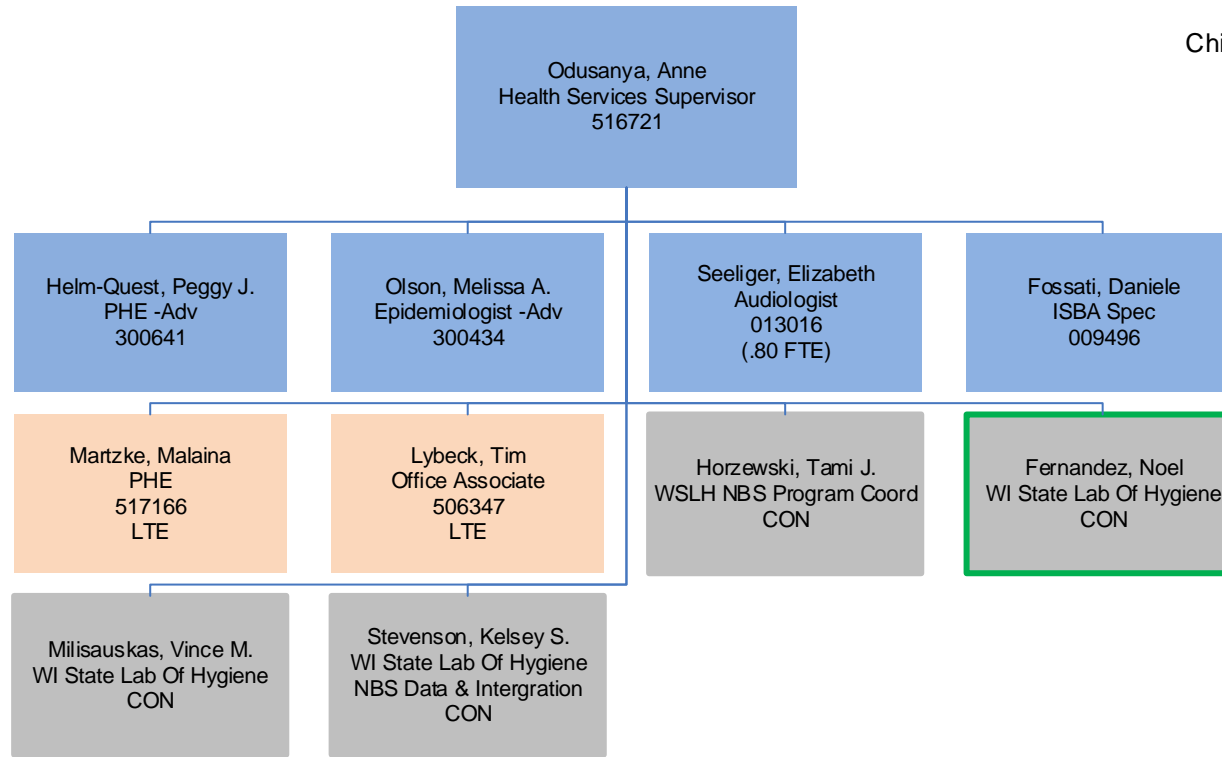

LEGEND:

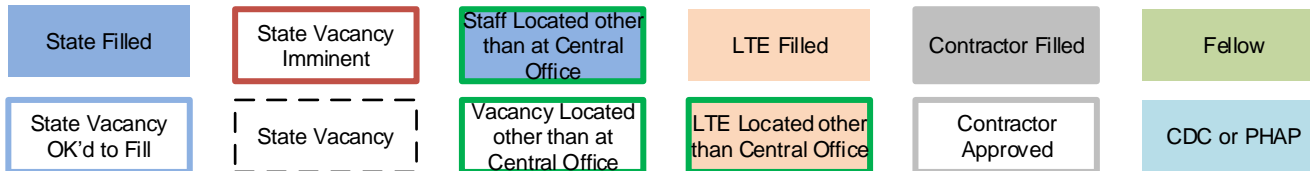

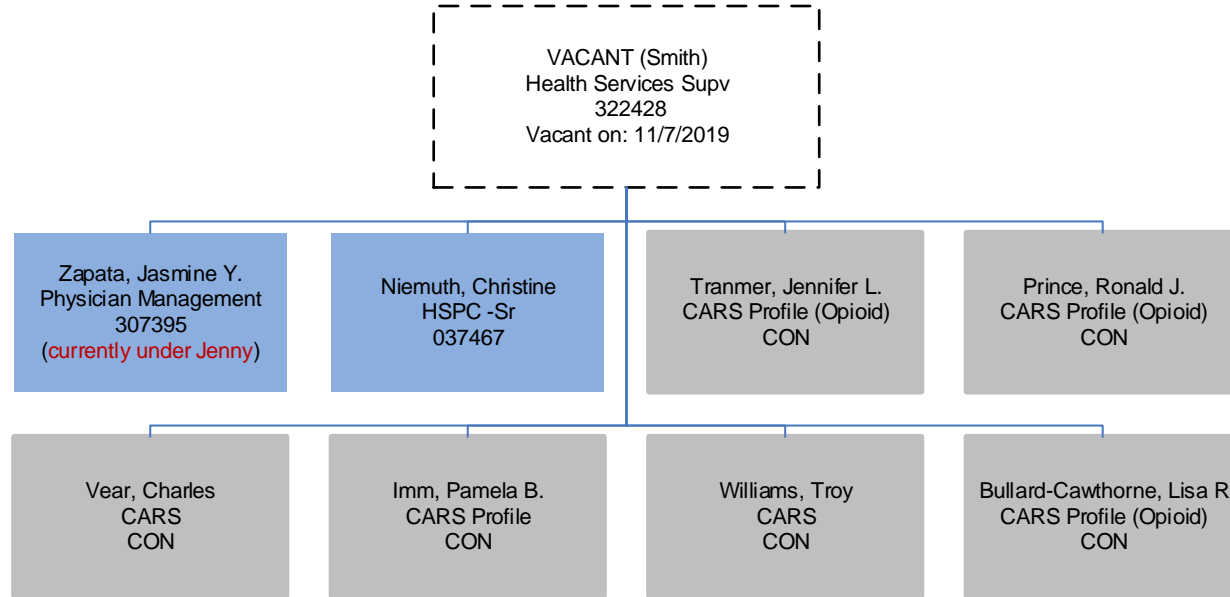

LEGEND:

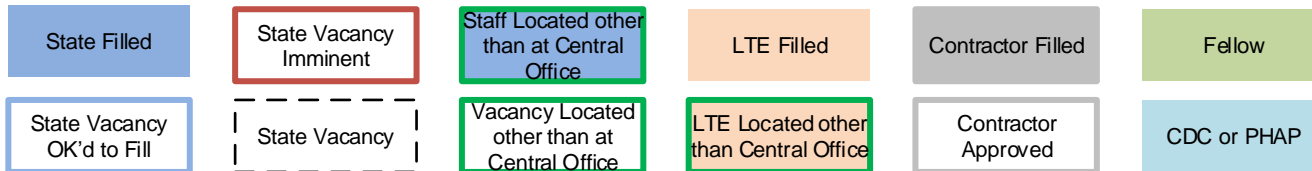



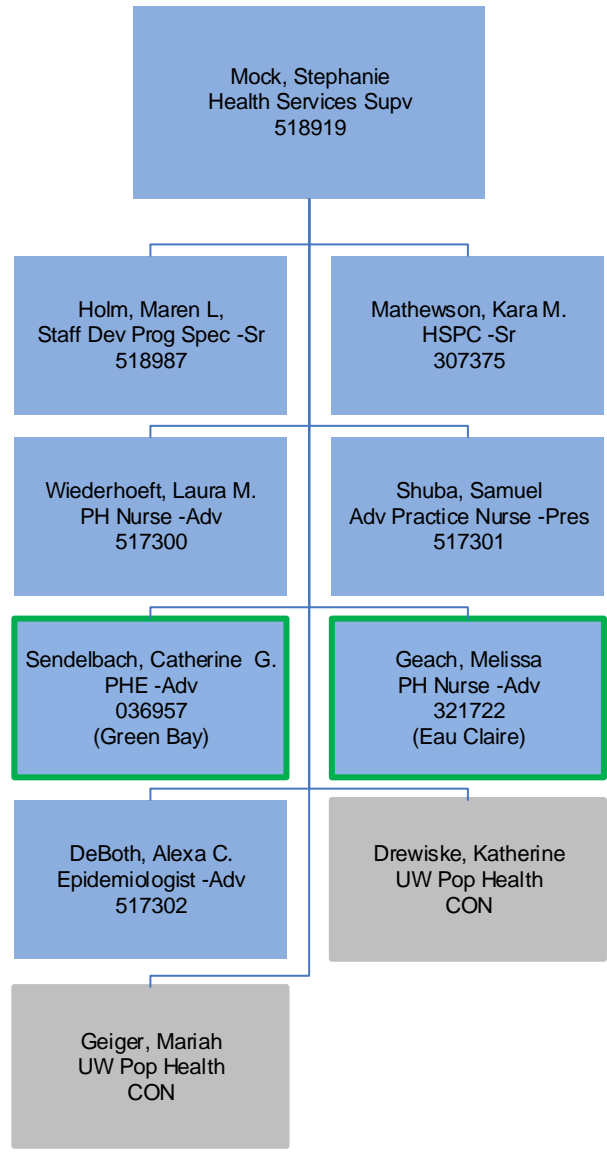

LEGEND:

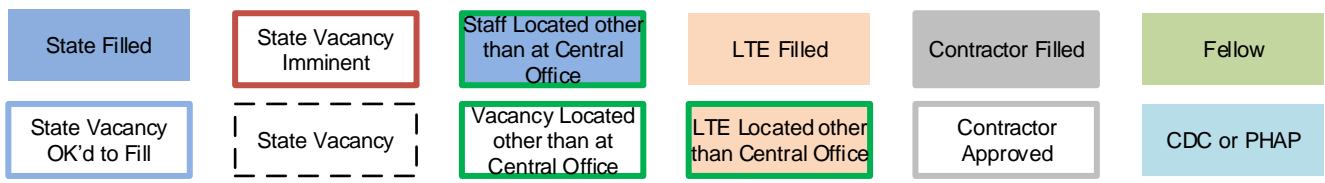

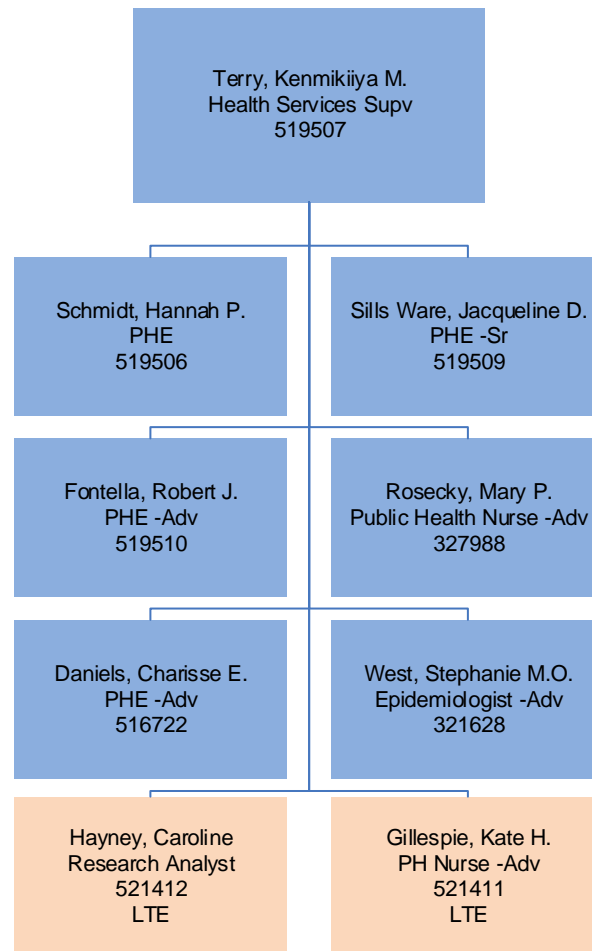

**LEGEND:**

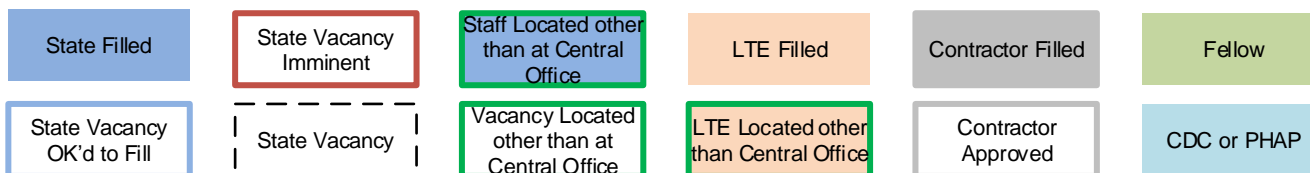

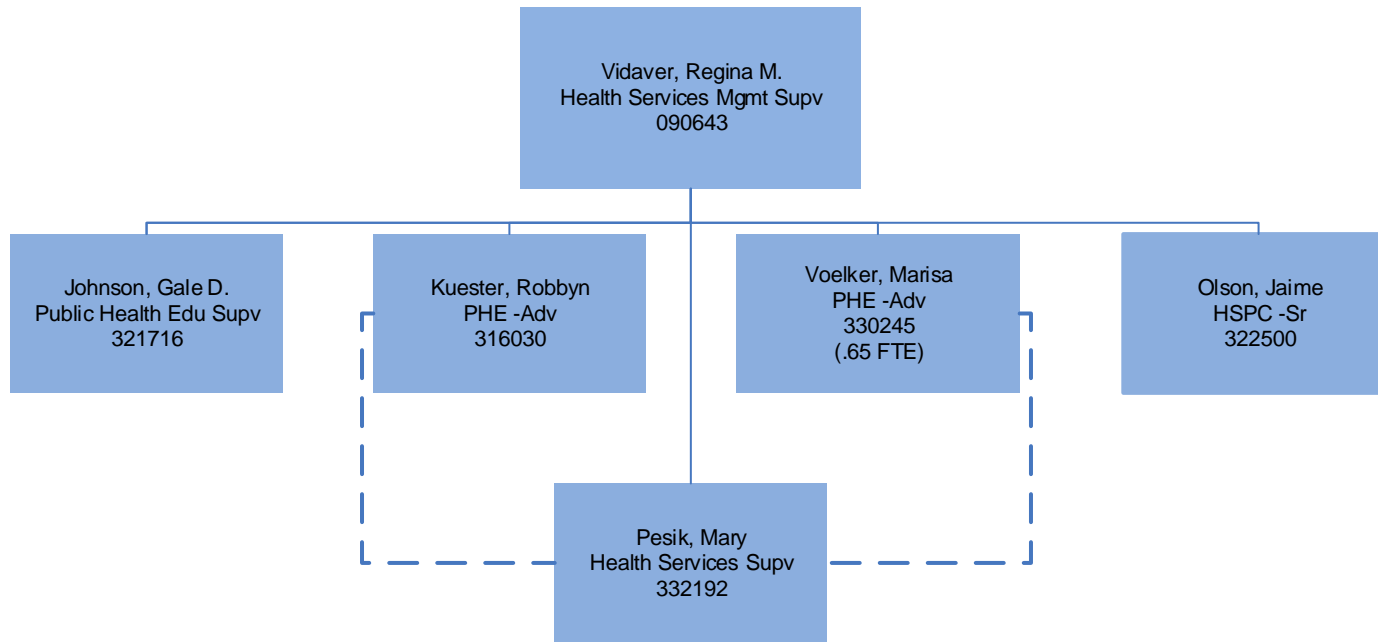

**LEGEND:**

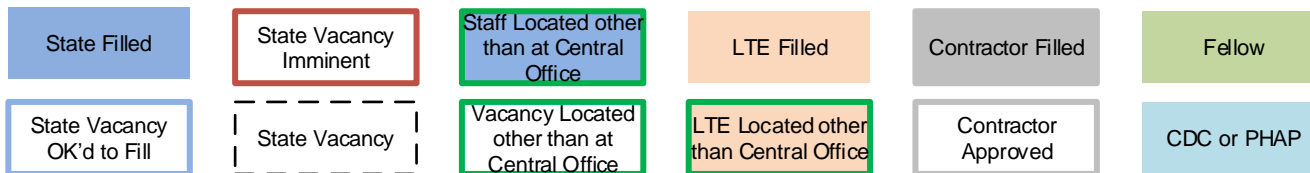

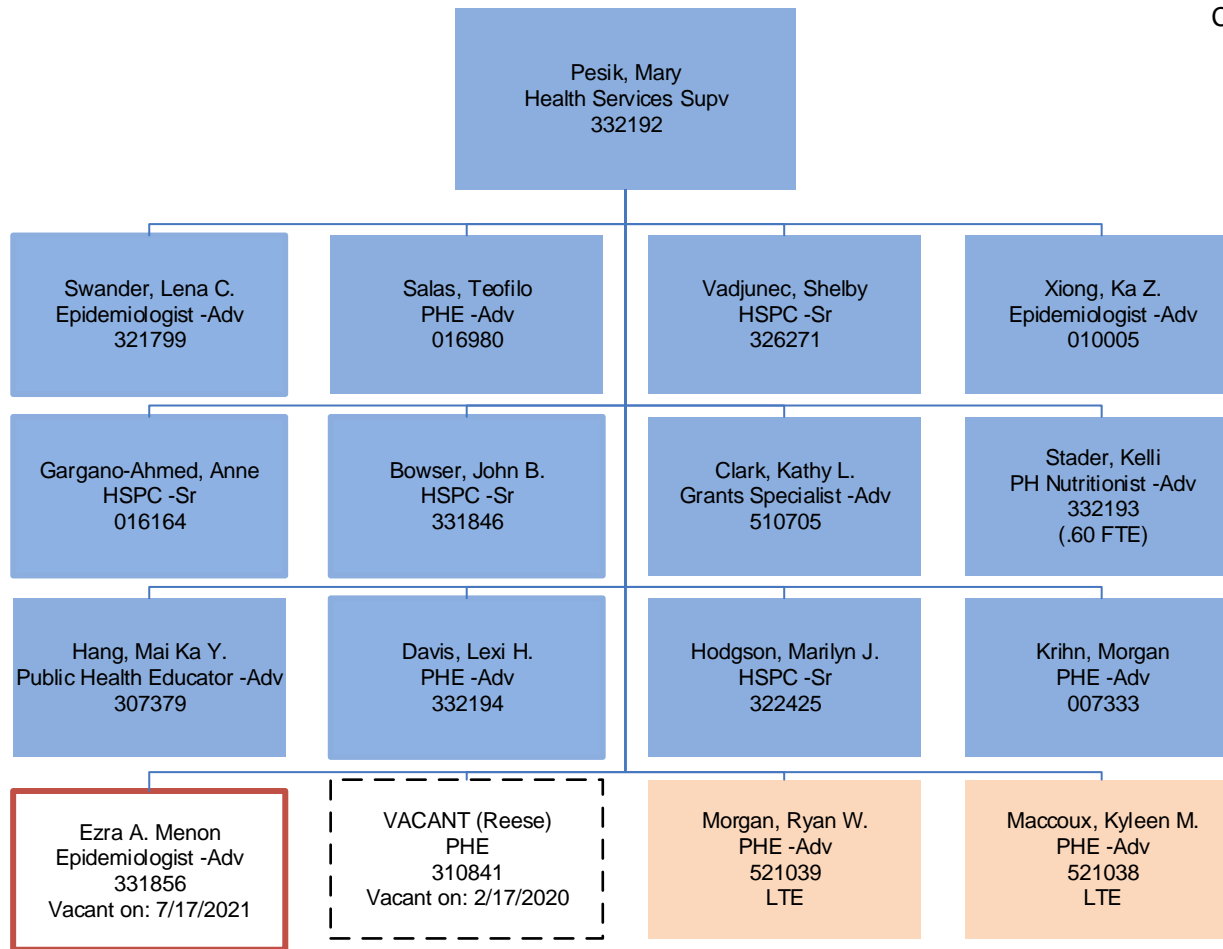

LEGEND:

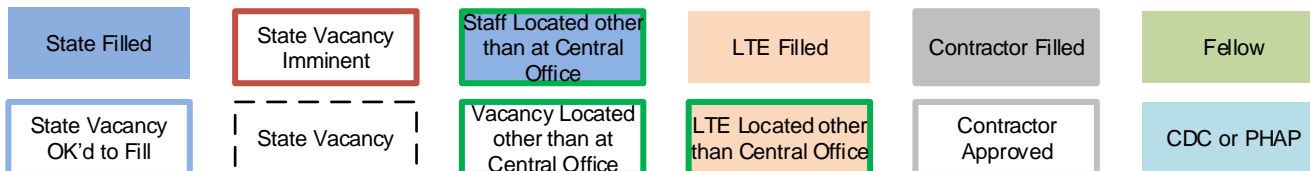

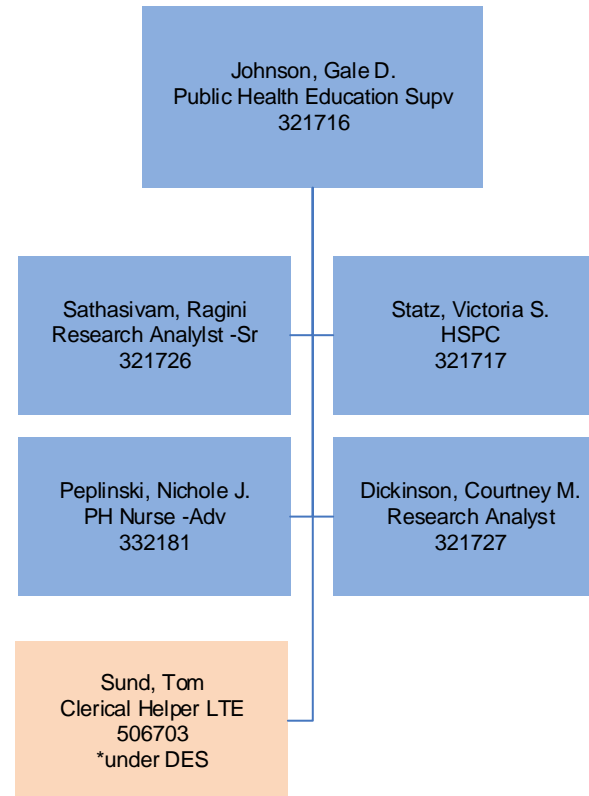

LEGEND:

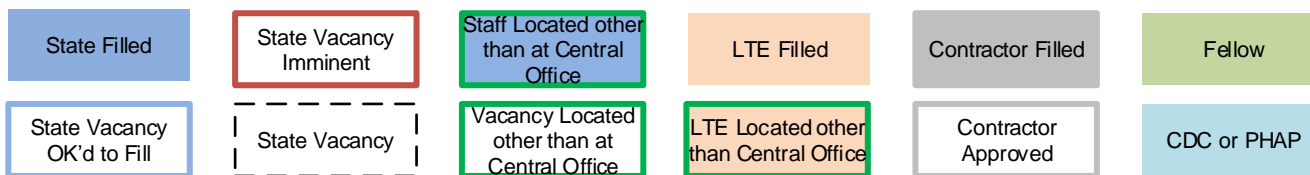

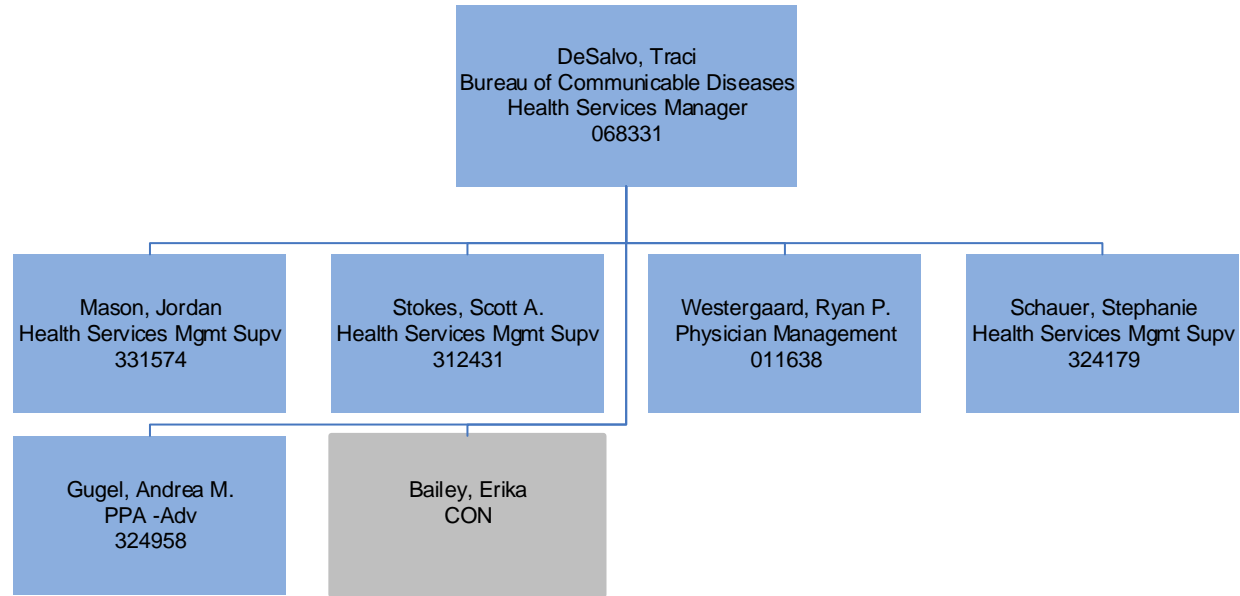

LEGEND:

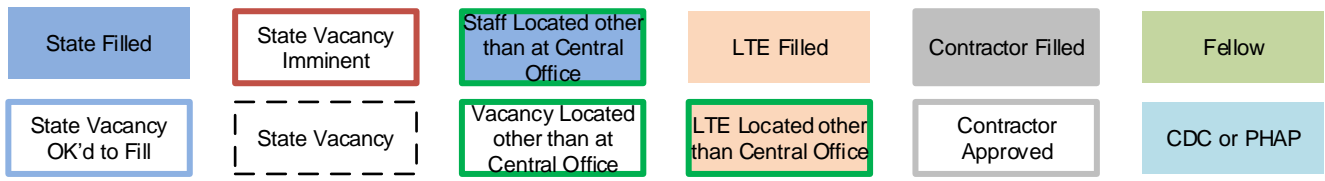

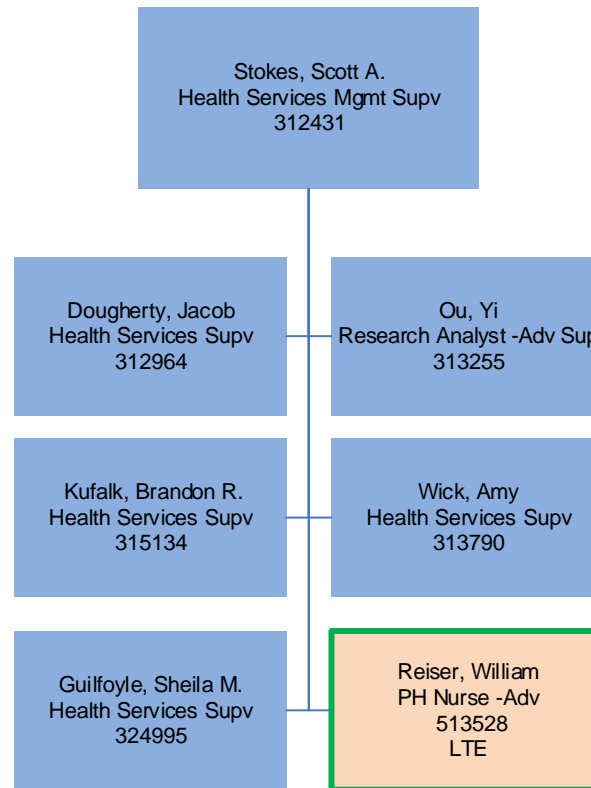

LEGEND:

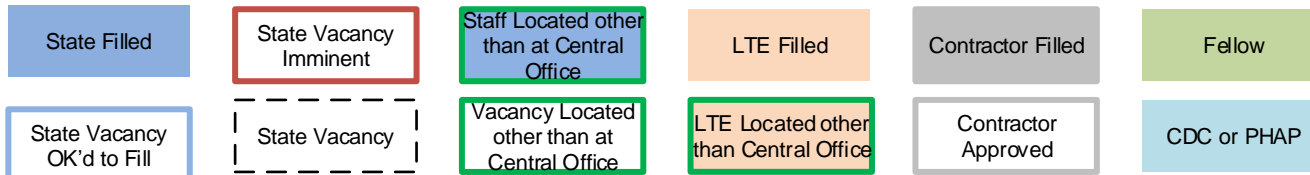

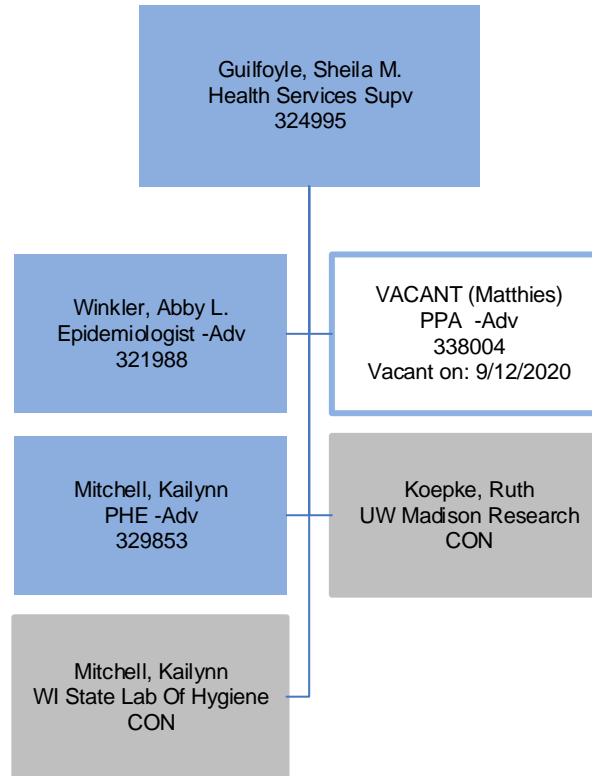

LEGEND:

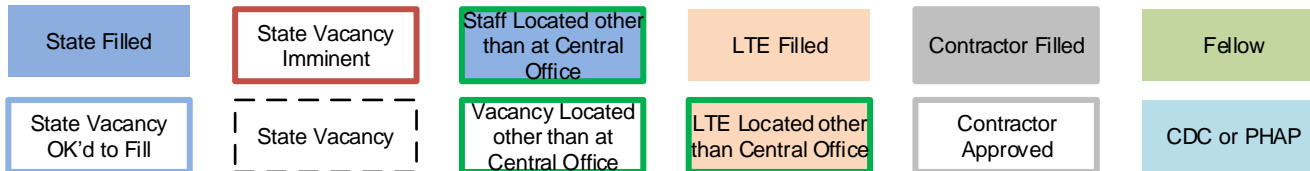



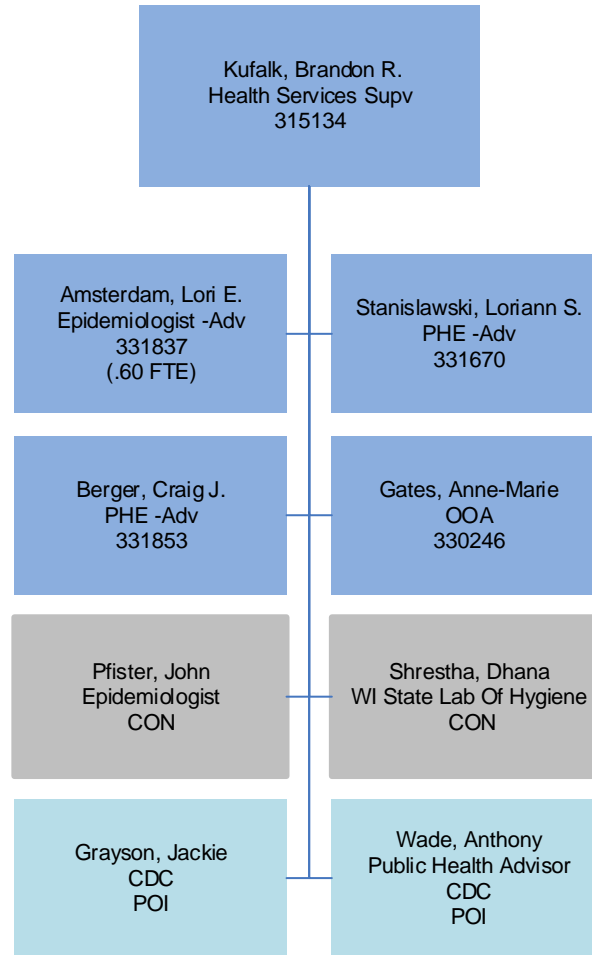

LEGEND:

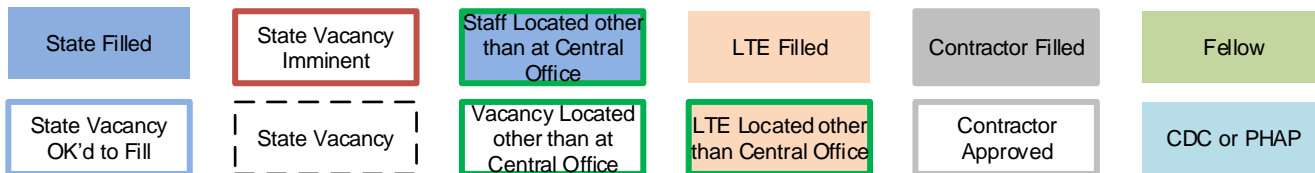

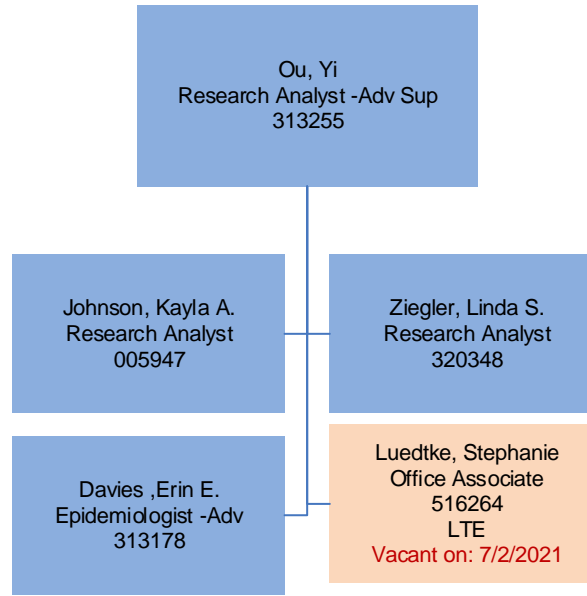

LEGEND:

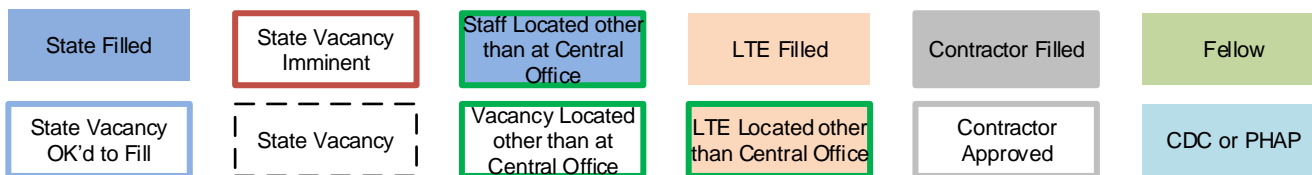

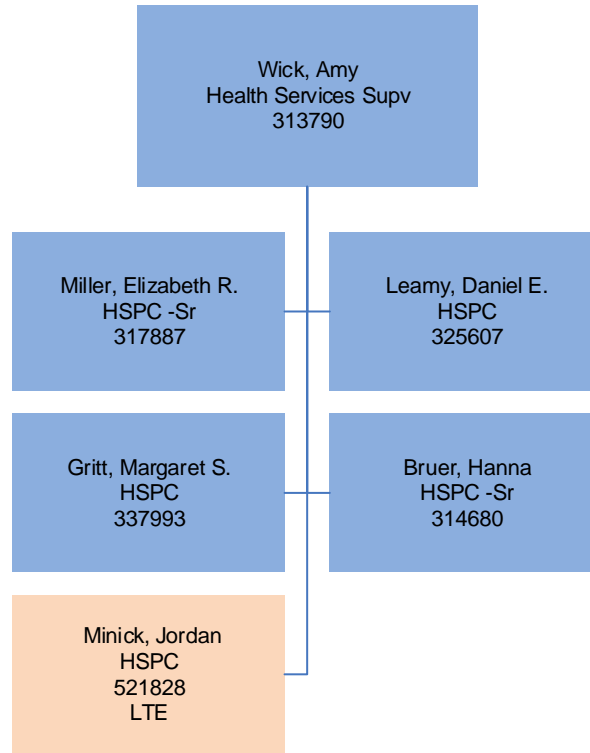

LEGEND:

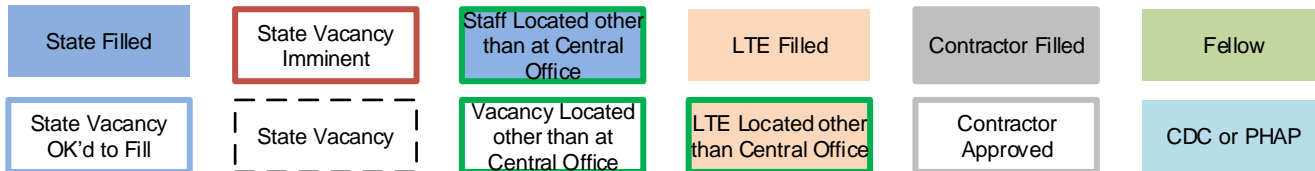

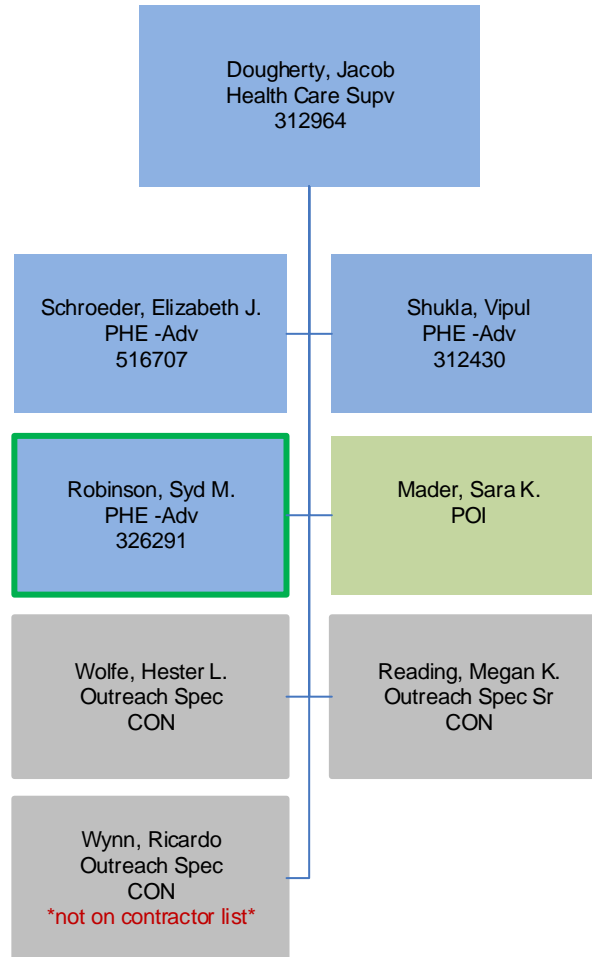

LEGEND:

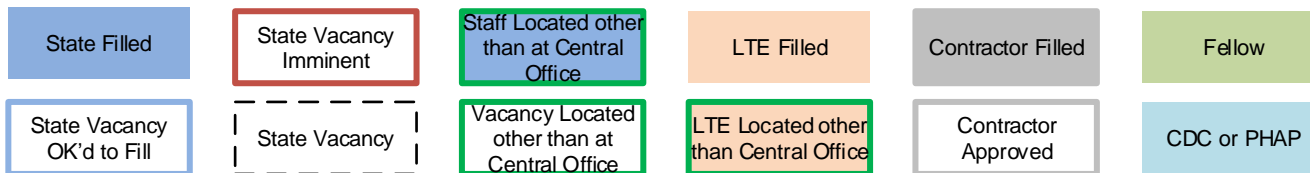

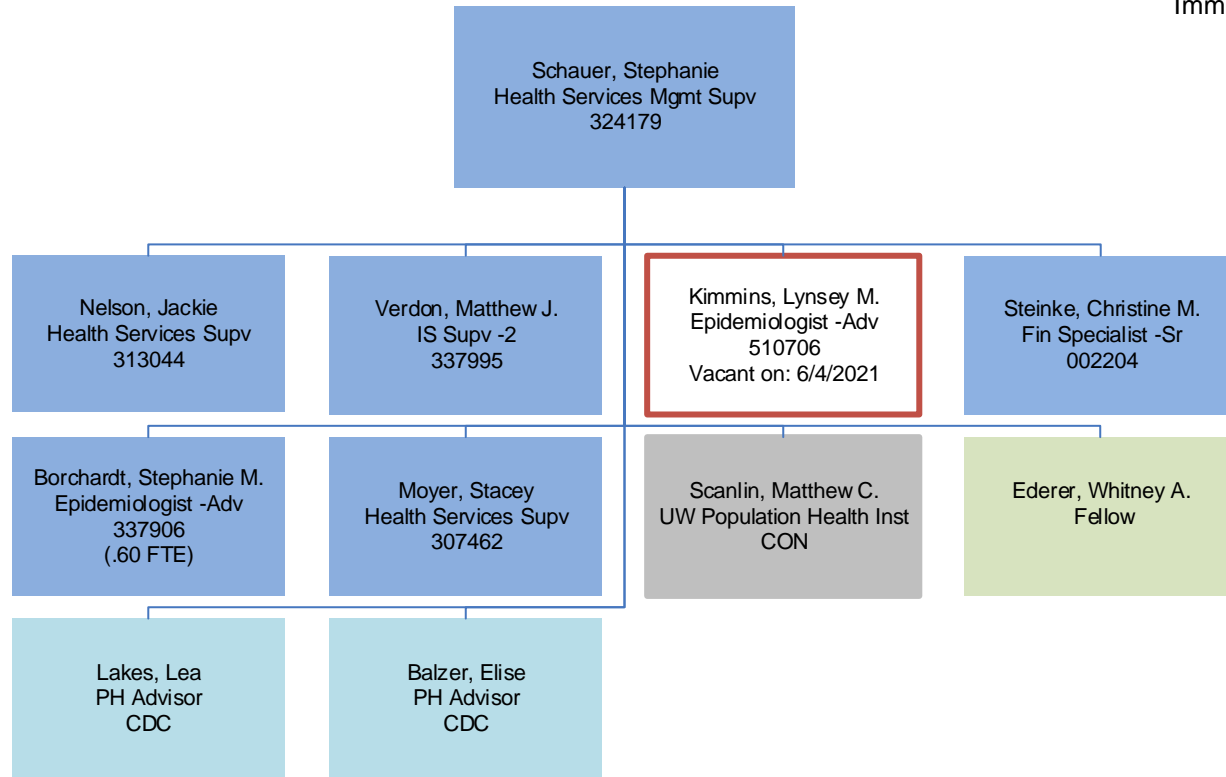

LEGEND:

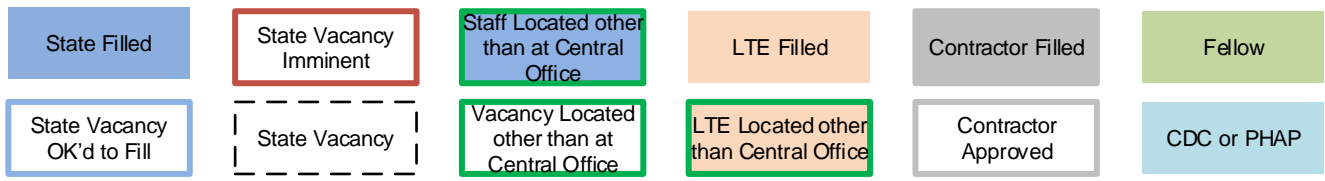

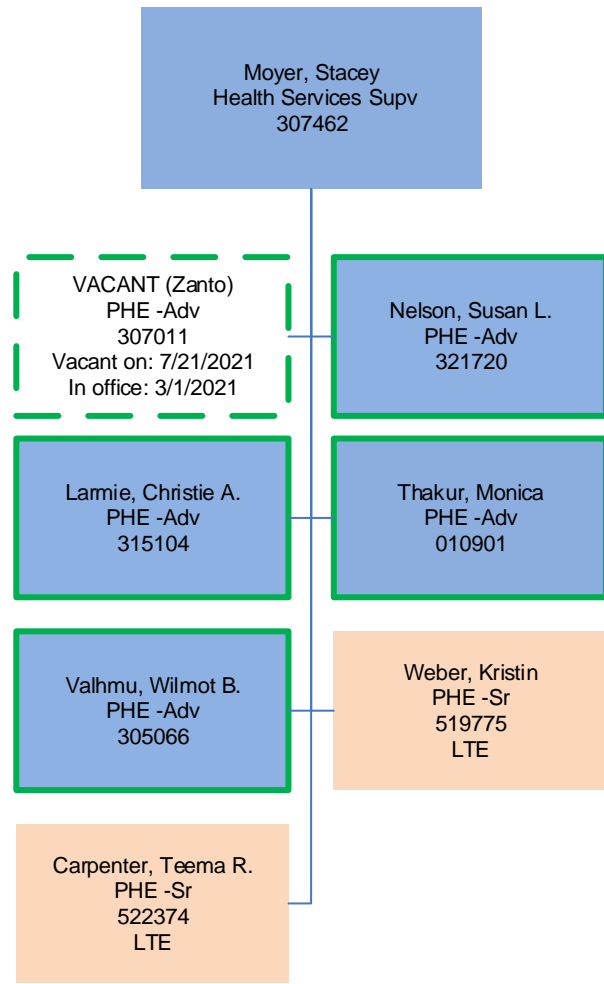

LEGEND:

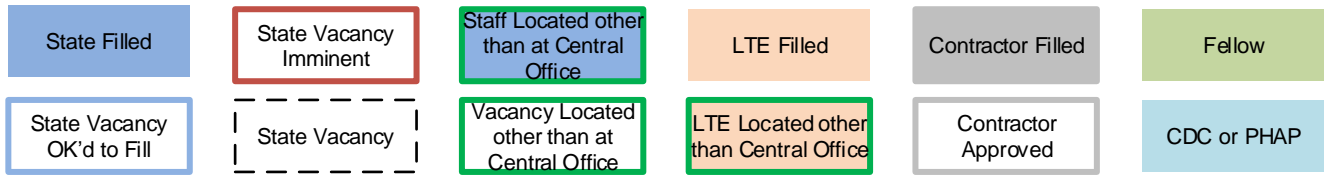

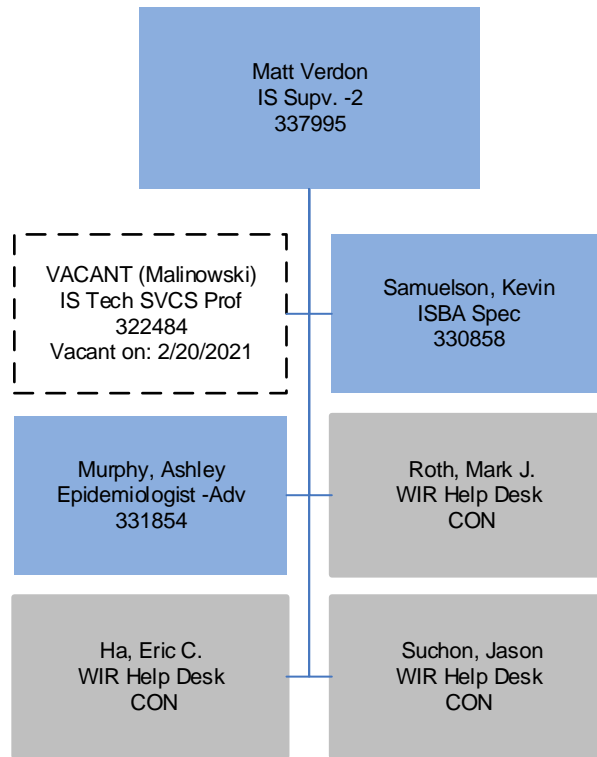

LEGEND:

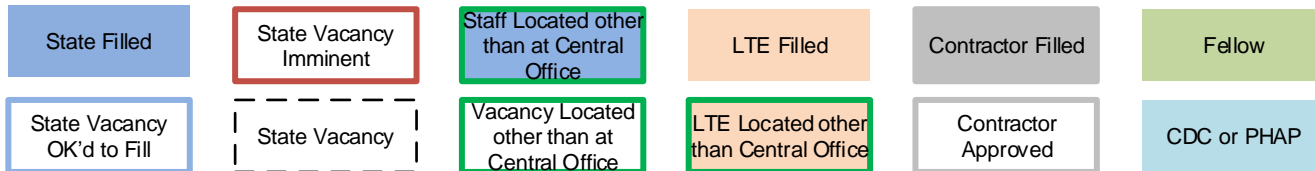

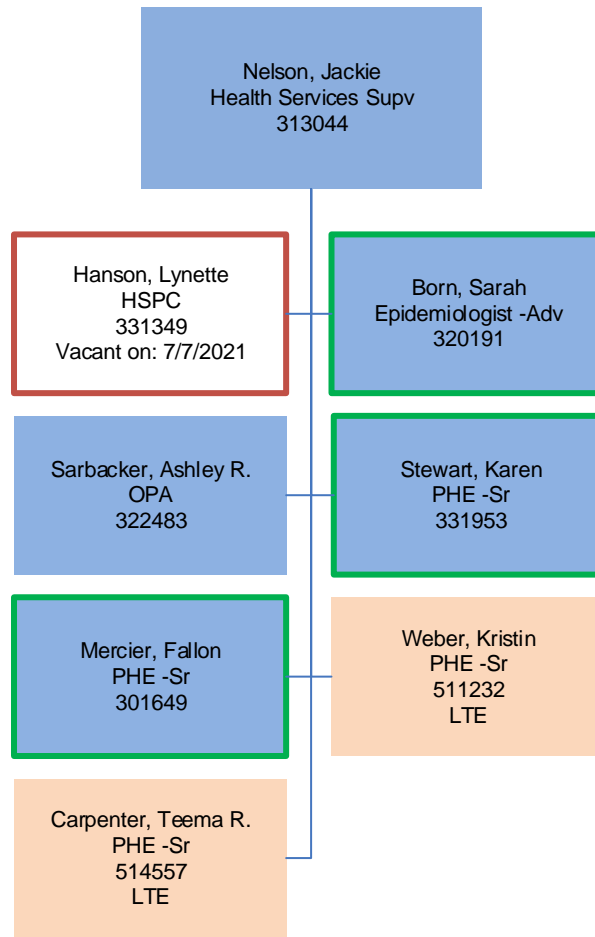

LEGEND:

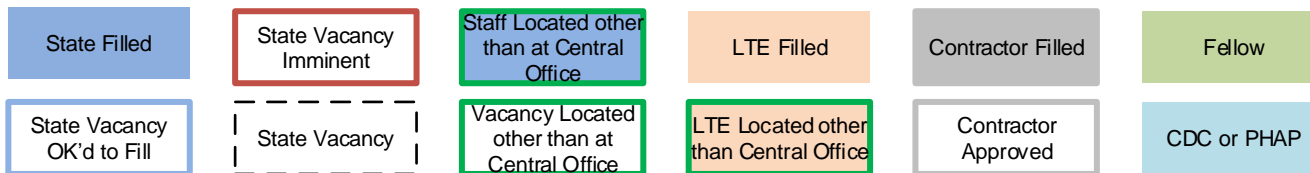



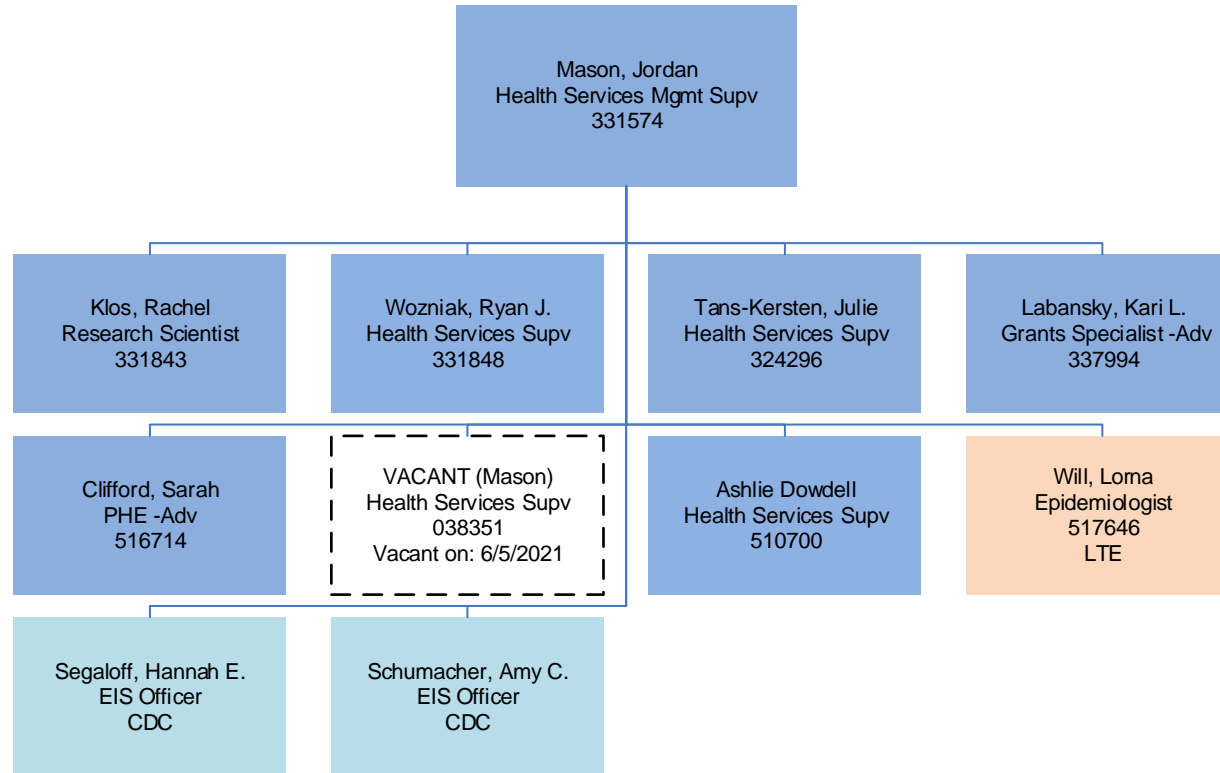

LEGEND:

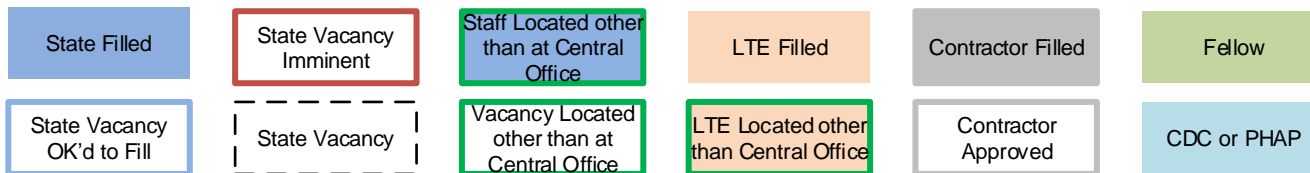

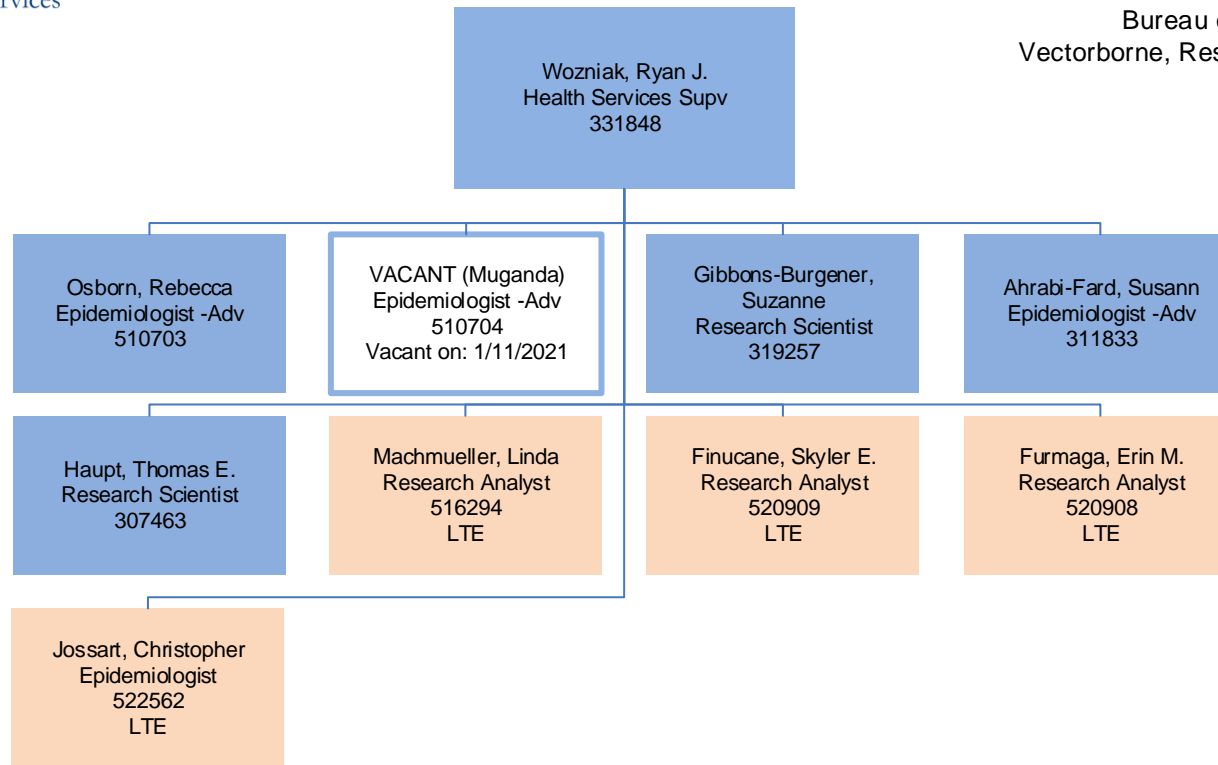

LEGEND:

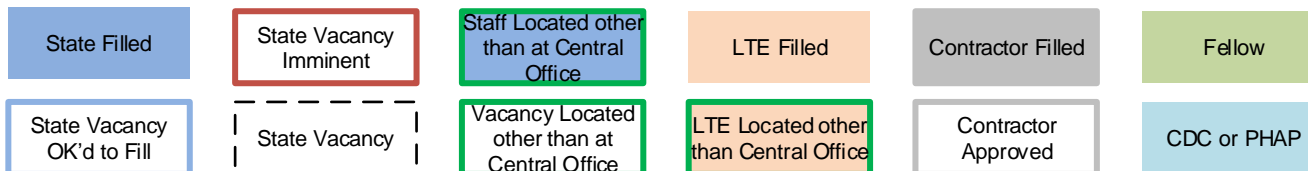

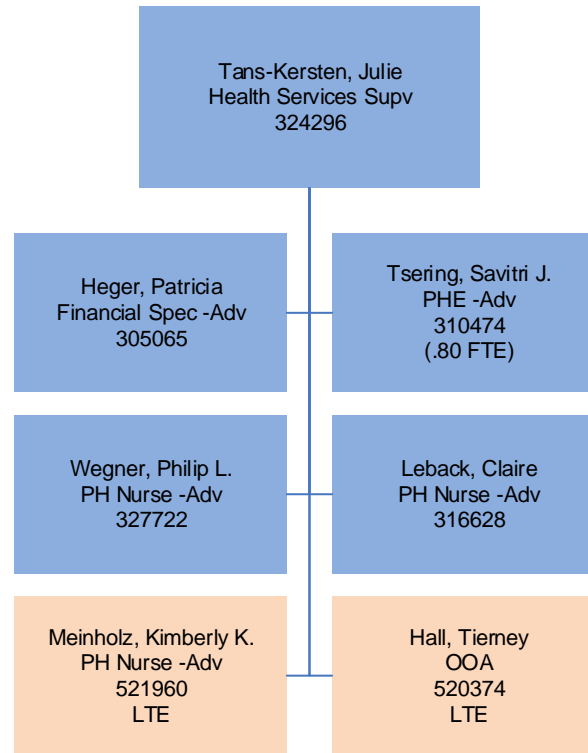

LEGEND:

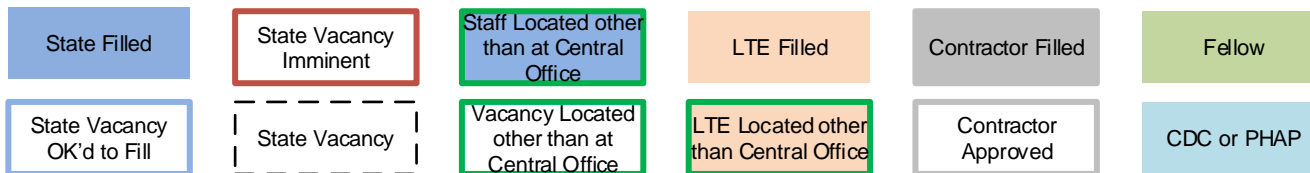

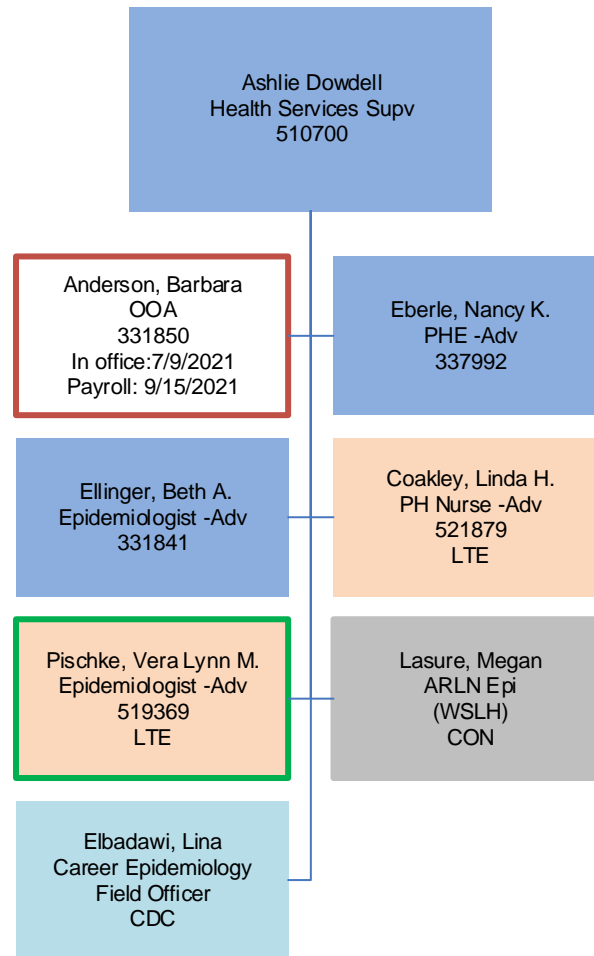

LEGEND:

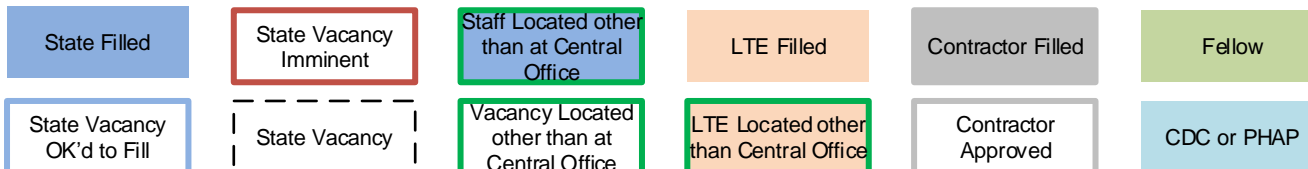

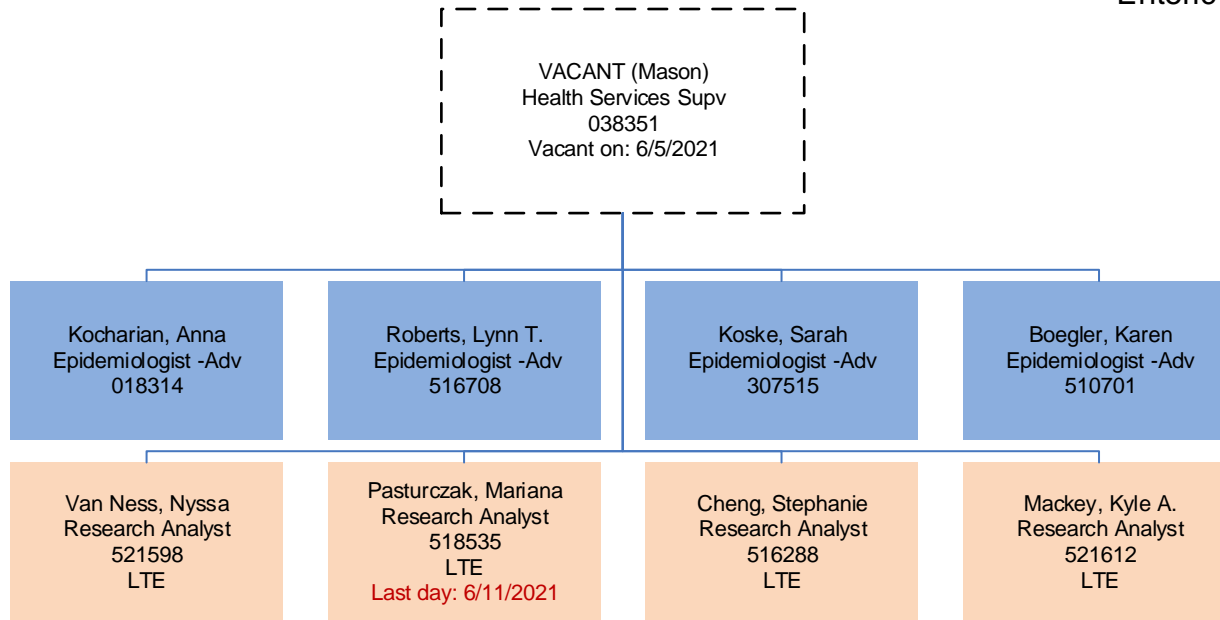

LEGEND:

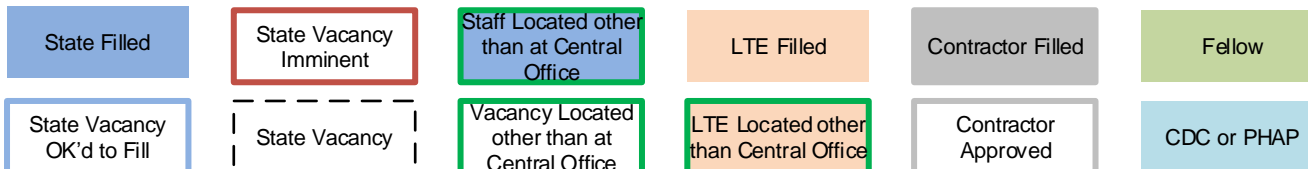

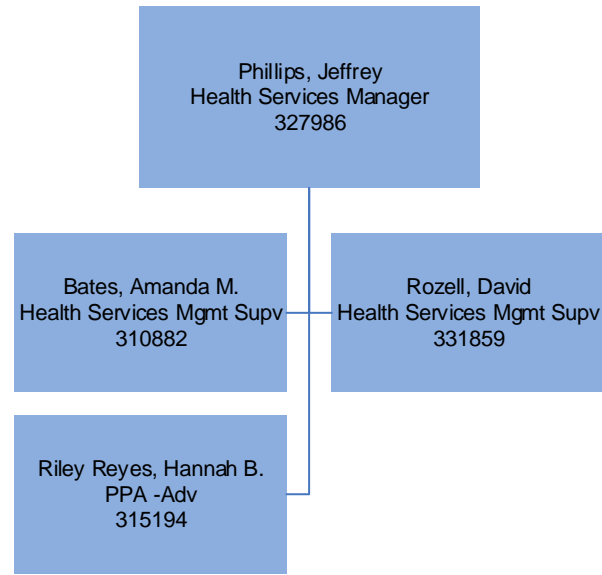

LEGEND:

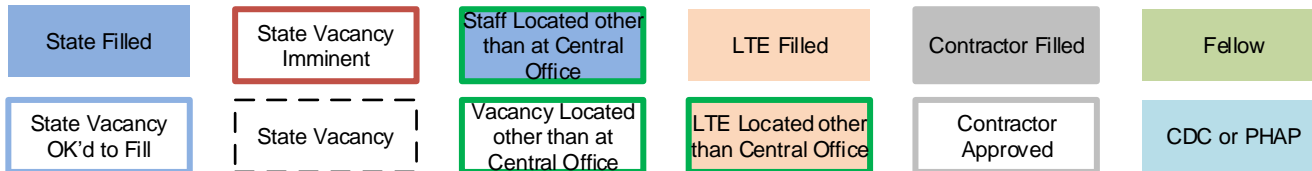

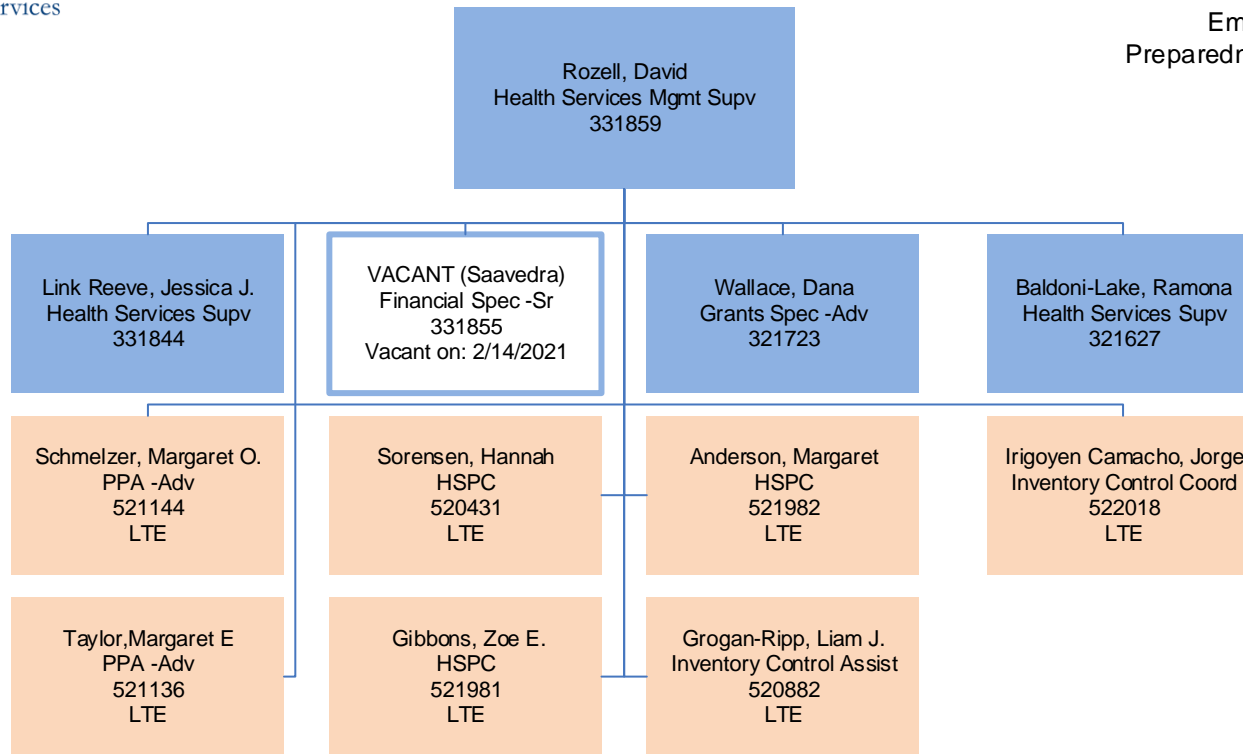

LEGEND:

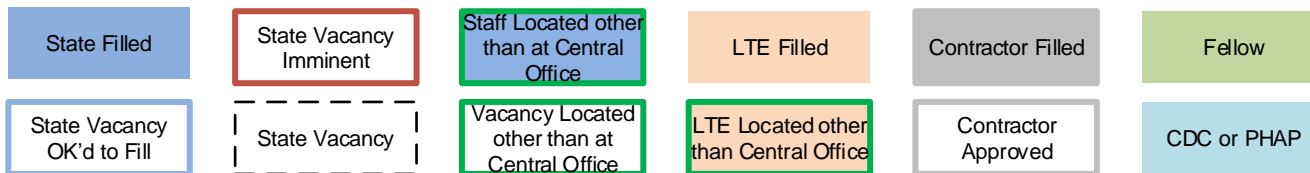

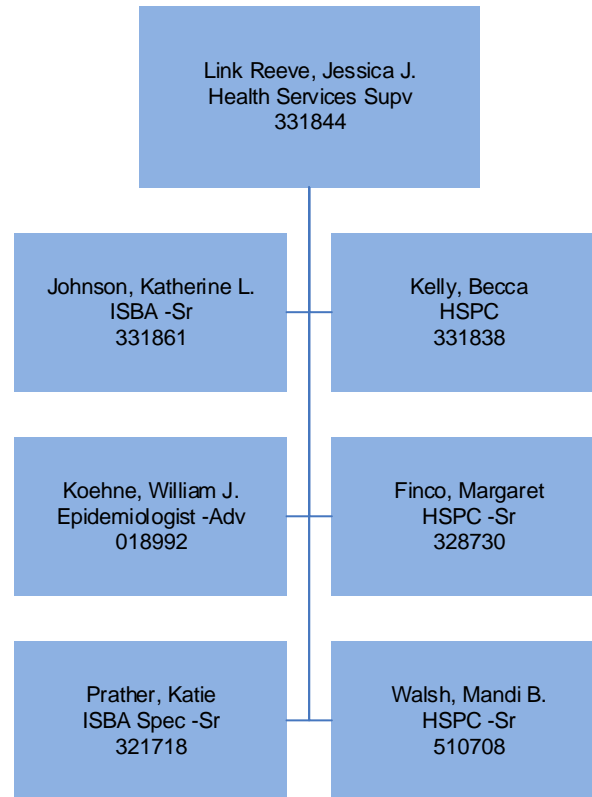

LEGEND:

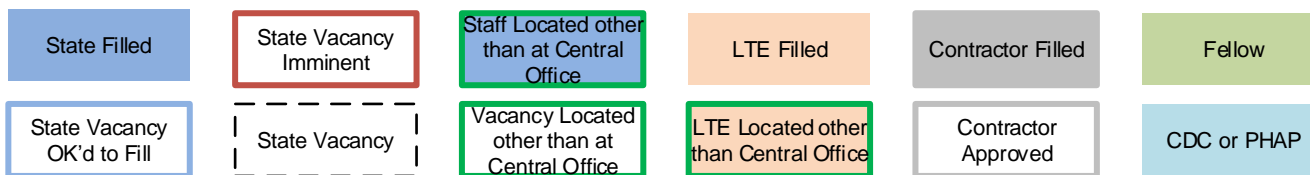



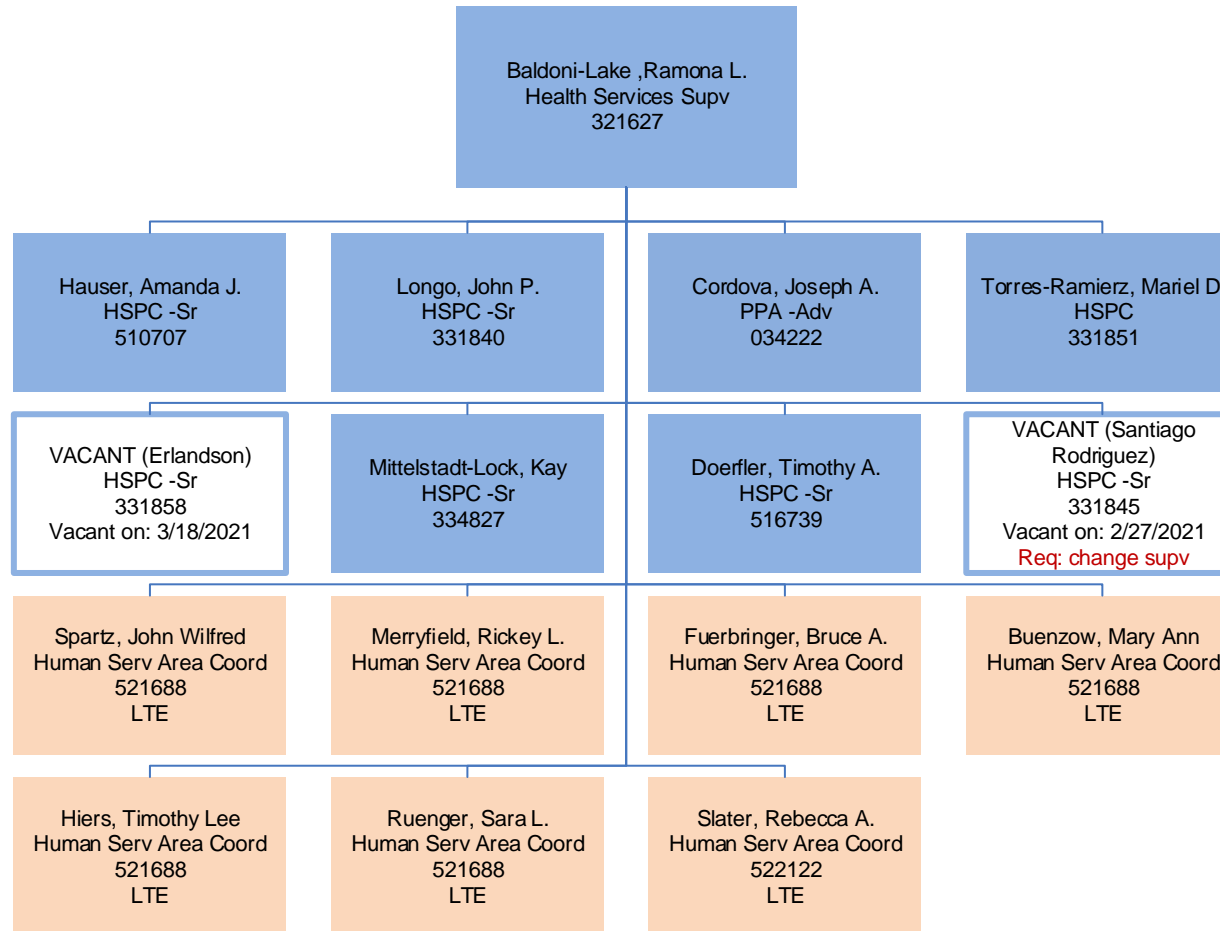

LEGEND:

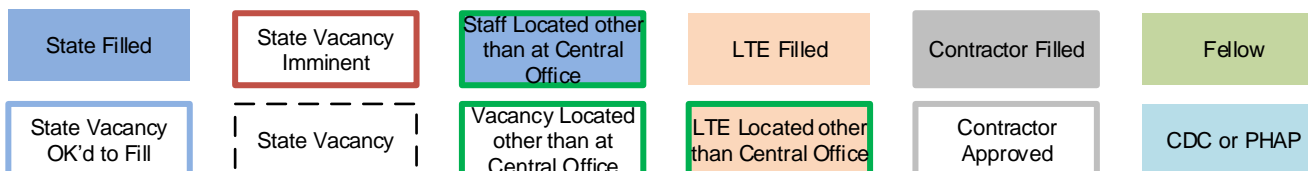

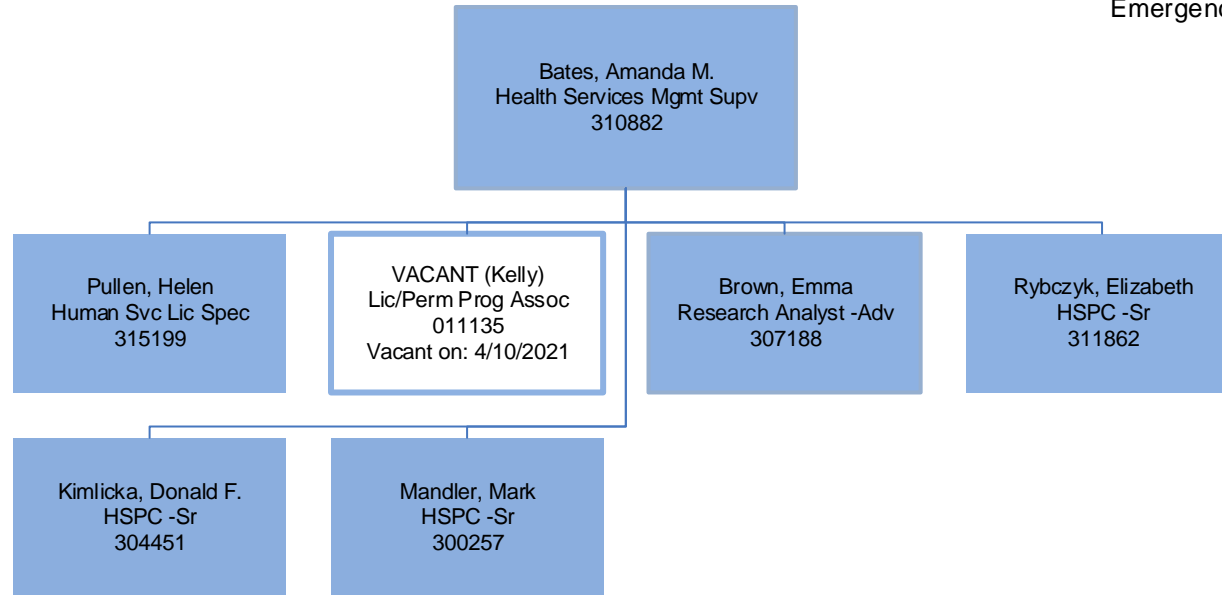

LEGEND:

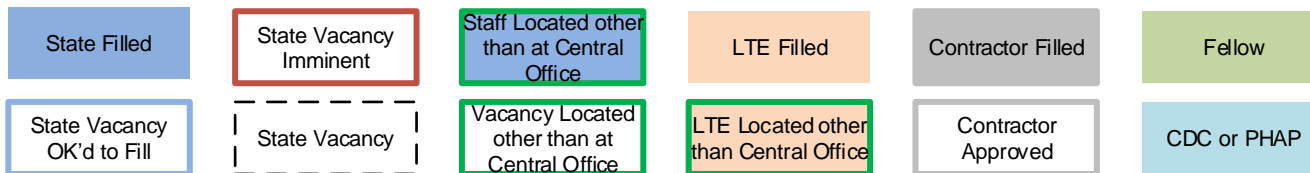

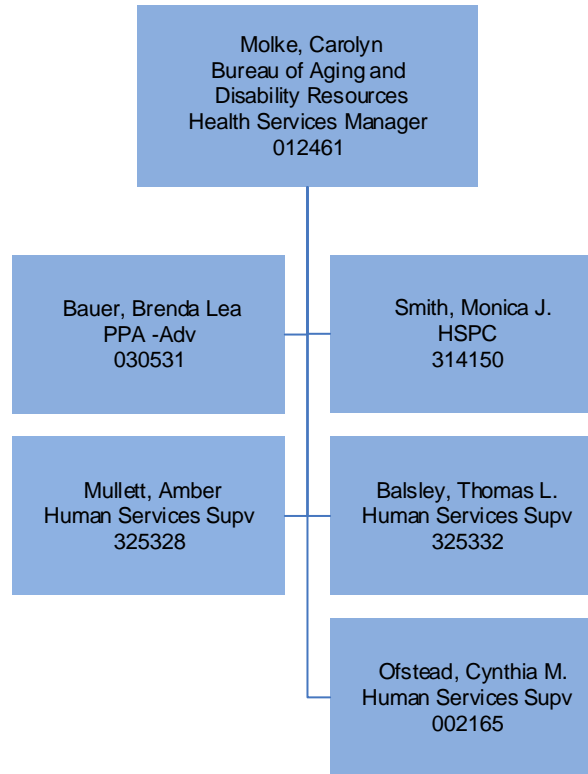

LEGEND:

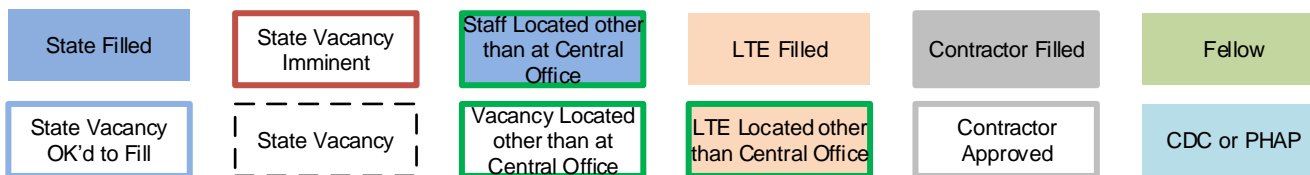

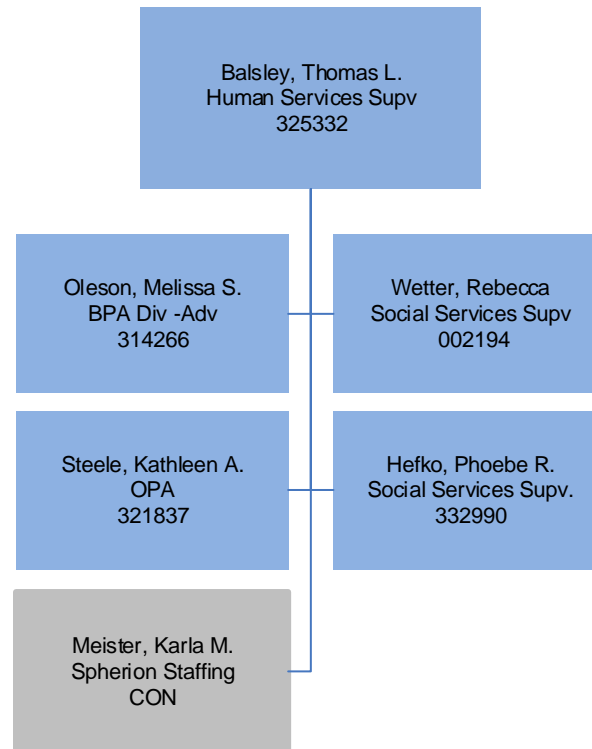

LEGEND:

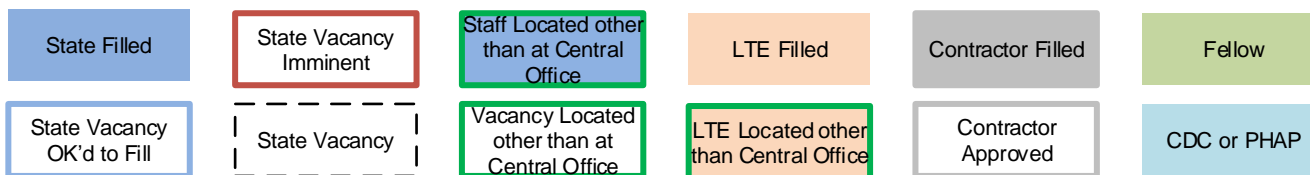

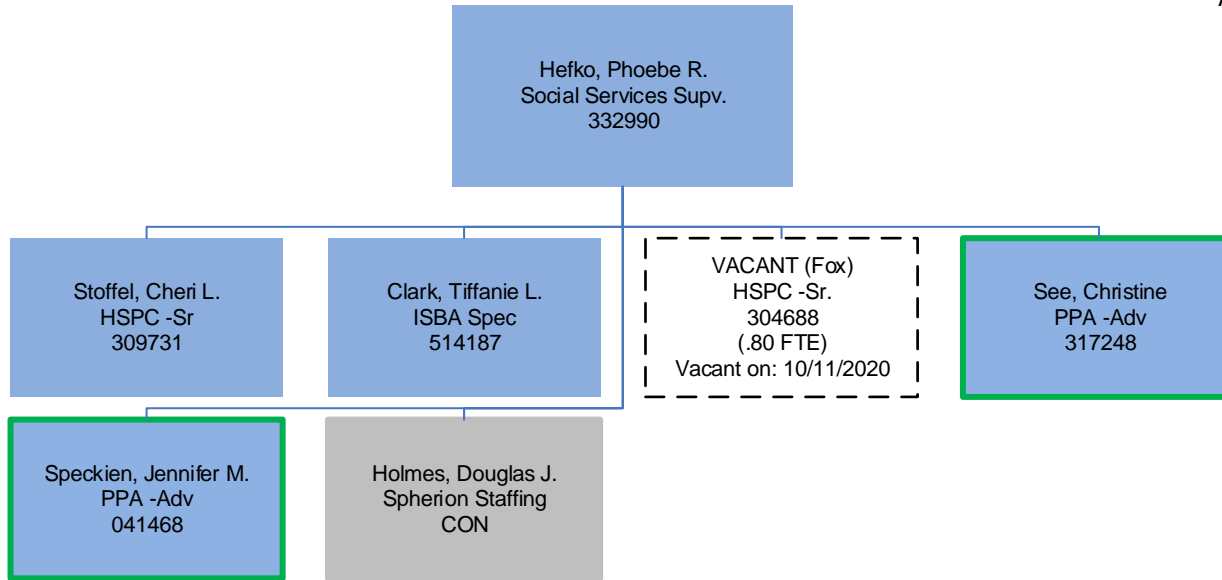

LEGEND:

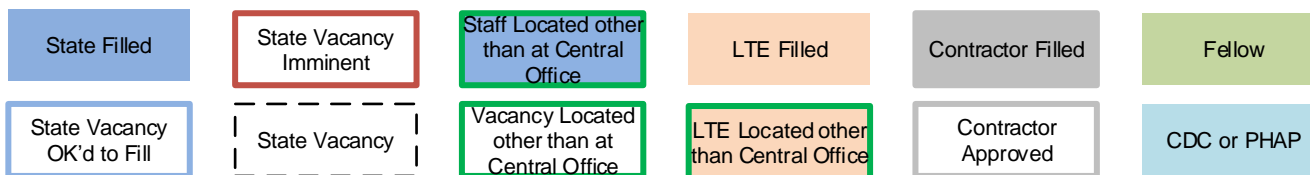

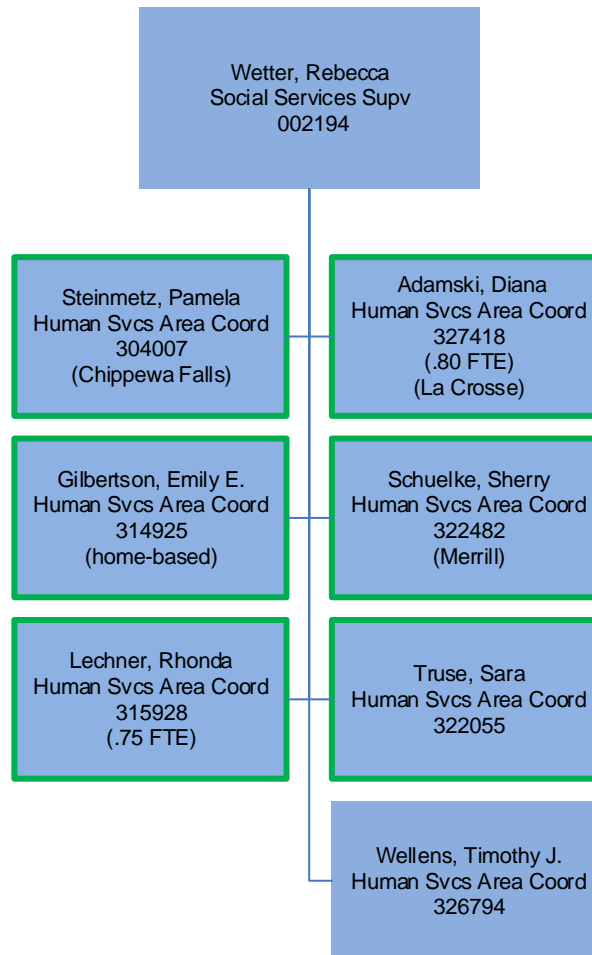

LEGEND:

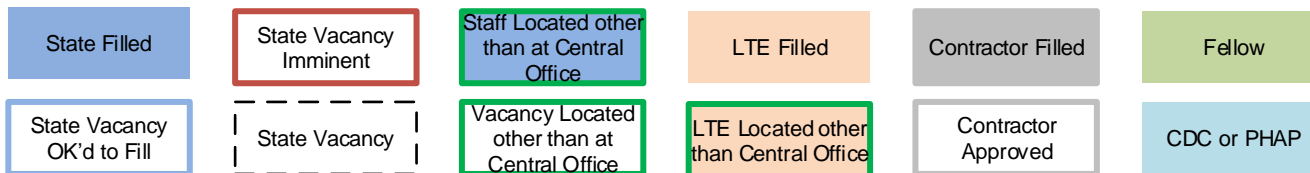

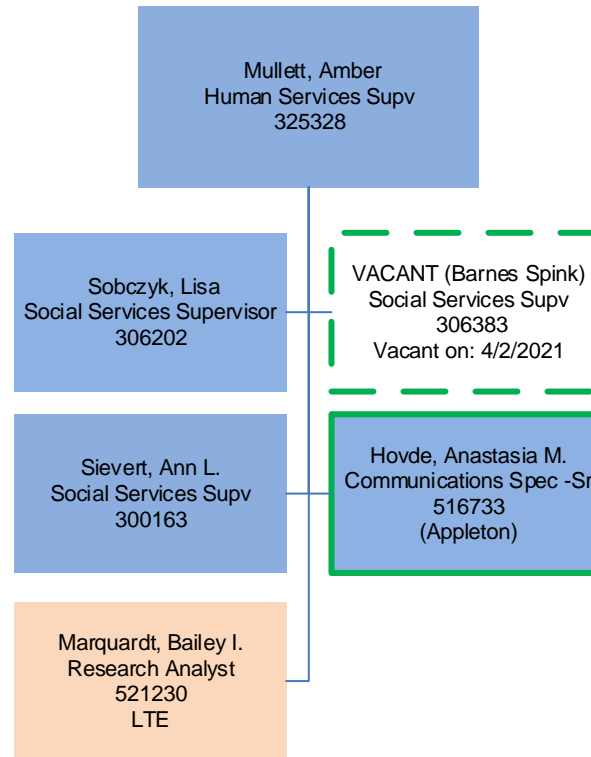

LEGEND:

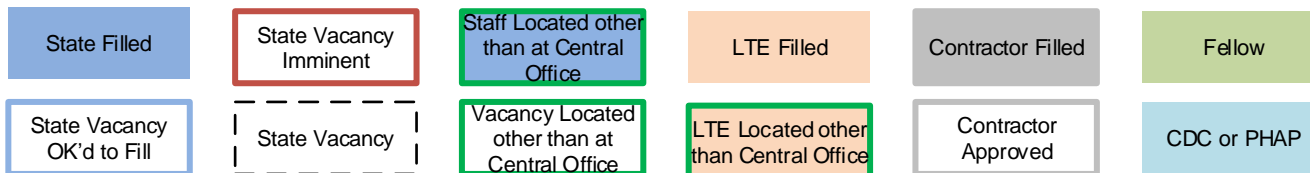

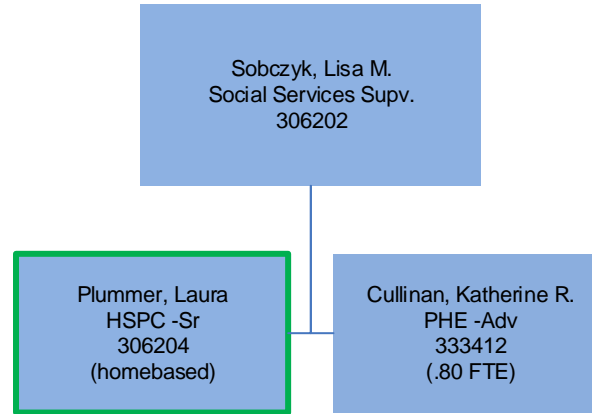

LEGEND:

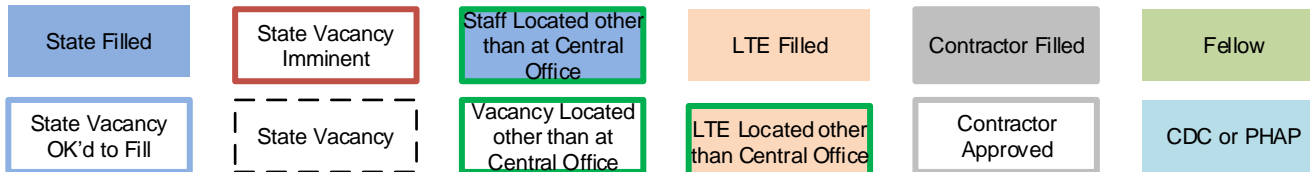



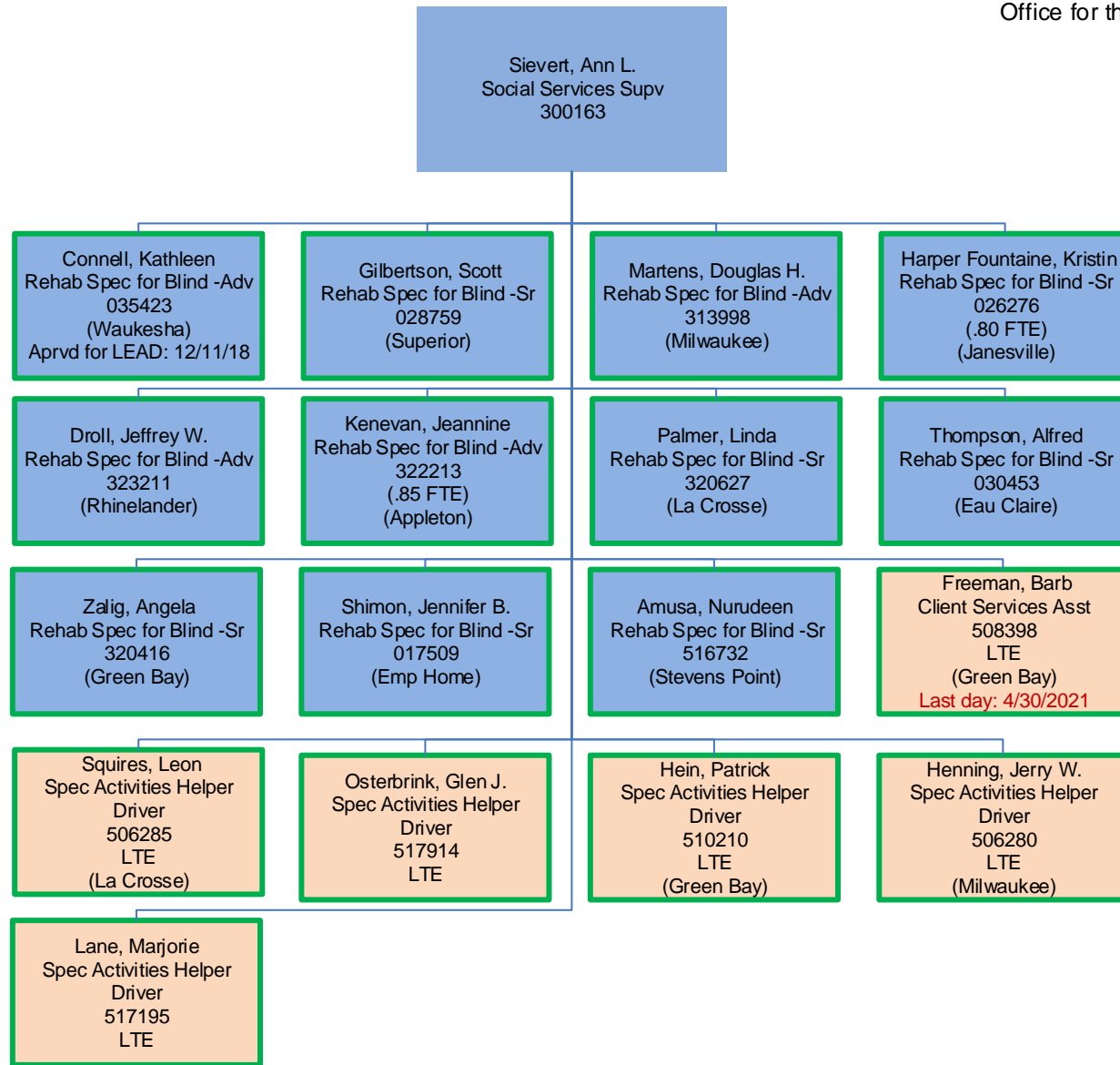

LEGEND:

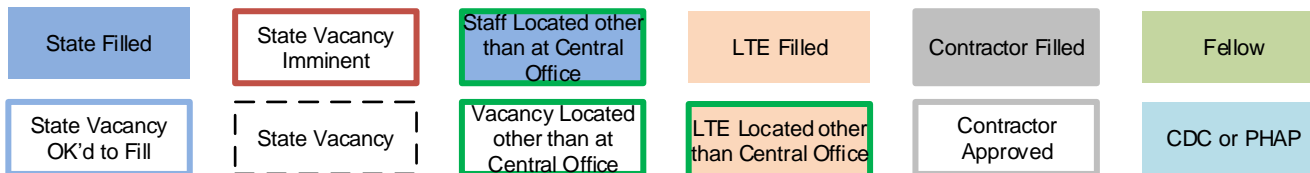

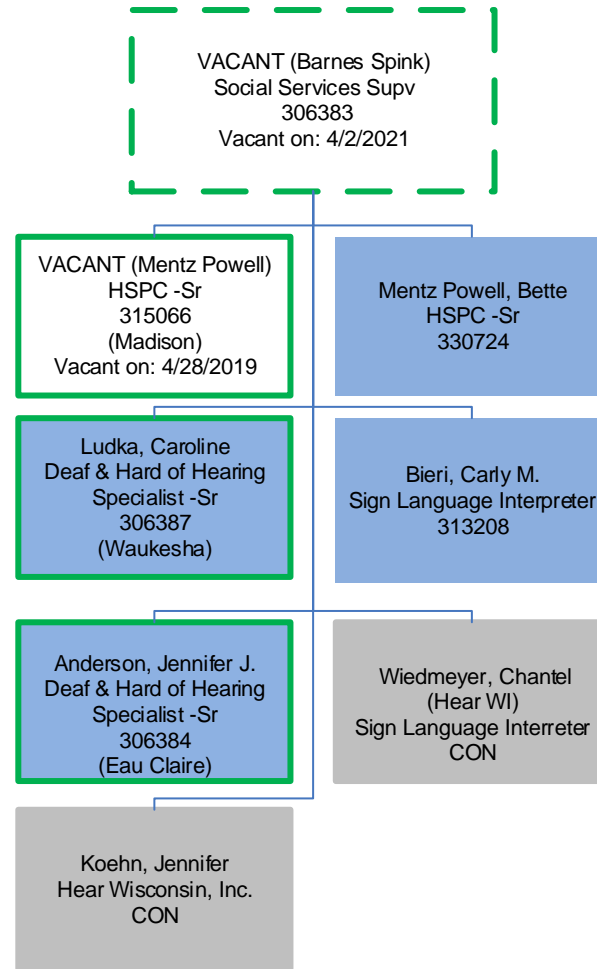

LEGEND:

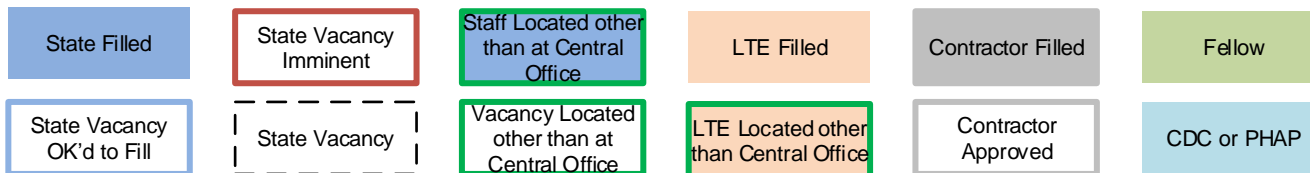

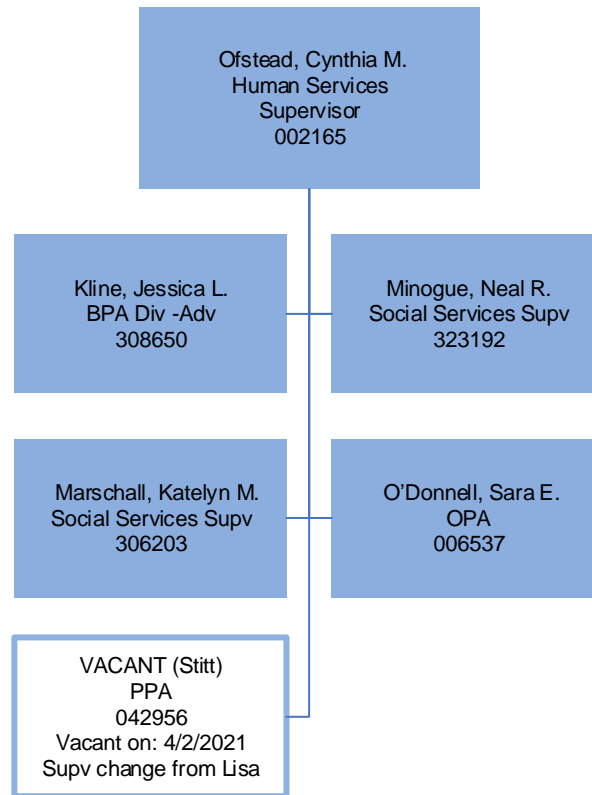

LEGEND:

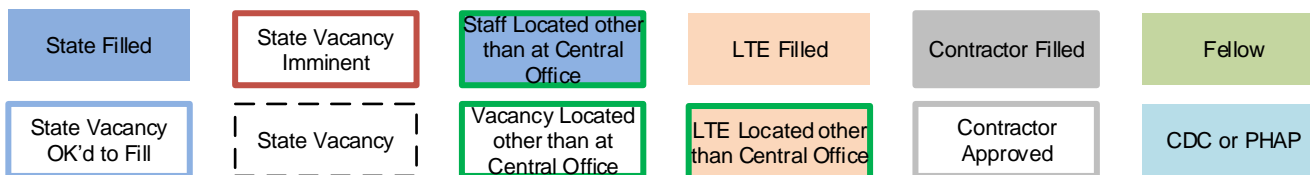

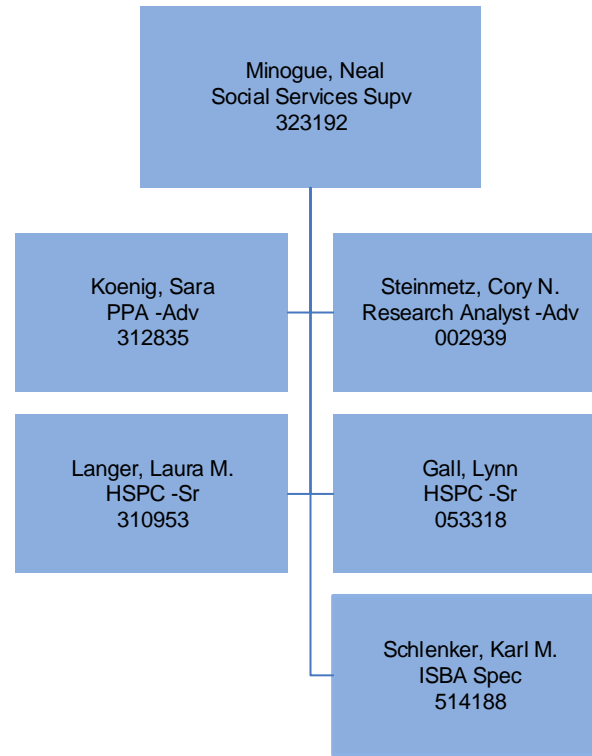

LEGEND:

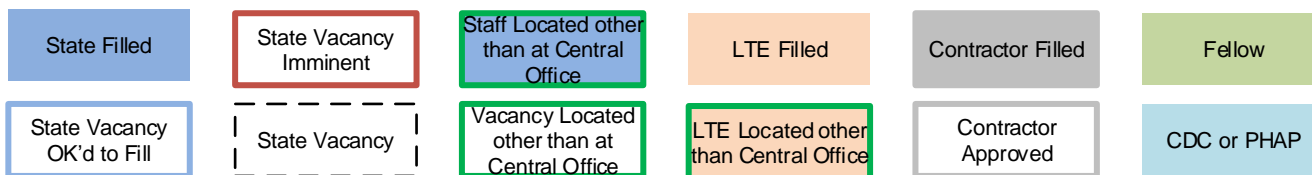

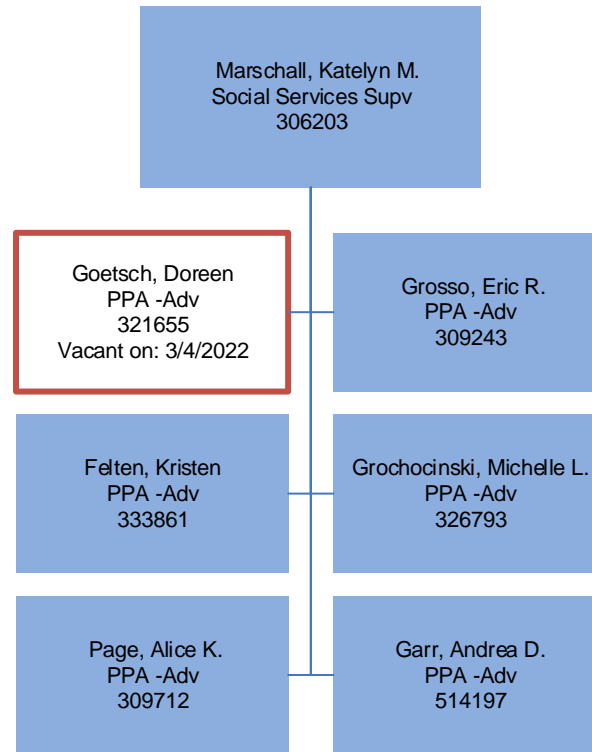

LEGEND:

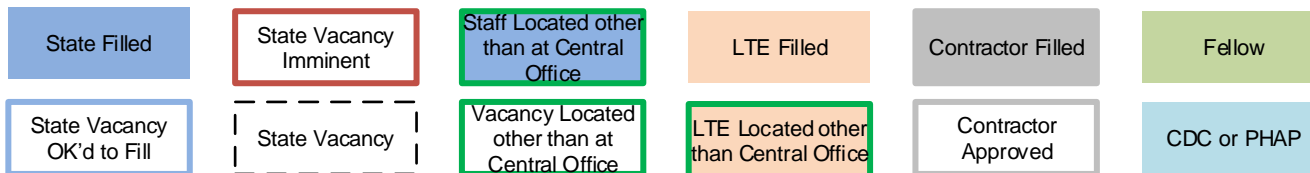



WISCONSIN DEPARTMENT  
*of* HEALTH SERVICES

# Aging and Disability Resource Center Modernization

Tom Balsley, Director, Office for Resource Center Development  
Jennifer Speckien, ADRC Policy Strategist

# Background

- Aging and Disability Resource Centers (ADRCs) were established in 1998.
- They have been available statewide since 2013.
- There are currently 47 ADRCs serving all 72 counties and 11 tribes.
- ADRCs provide information and resources so individuals can make informed decisions.
- Demand for ADRC services grows every year.

# Project Goals

- Improve access to ADRC resources.
- Increase awareness of ADRCs throughout Wisconsin.
- Diversify and modernize ADRC services with a focus on equity.
- Meet the increasing demand for ADRC resources and services.



# Project Components

- Virtual resource platform
- Statewide marketing and outreach campaign

# Virtual Resource Platform

- Develop a statewide online resource network for customers.
- Improve access to resources for:
  - long-distance caregivers
  - those who prefer to research information independently
  - customers with other barriers
- Obtain resource information 24/7.
- Explore self-service options for specific services.

# Statewide Marketing and Outreach Campaign

- Implement a coordinated, statewide marketing and outreach campaign to:
  - Promote the virtual resource platform.
  - Promote local ADRCs.
- Re-brand ADRCs in a way that people will self-identify with to promote early access to information and resources.

# Estimated Project Timeline

- **2022**
  - Stakeholder engagement and input.
  - RFP process for technology options.
  - Complete comprehensive project plan.
- **2023**
  - Development of the virtual resource platform.
  - Development of the statewide marketing campaign.
- **2024**
  - Launch the virtual resource platform and marketing campaign.

# Questions?

Questions and comments can be directed to [Jennifer Speckien](#).



WISCONSIN DEPARTMENT  
*of* HEALTH SERVICES

# ARPA HCBS Innovation Grants

Sue Recob, Project Manager  
Kevin Coughlin, Project Lead



# Agenda

- Project Description
- Objectives
- Eligibility
- Vendor Selection
- Timeline
- Questions

# Project Description

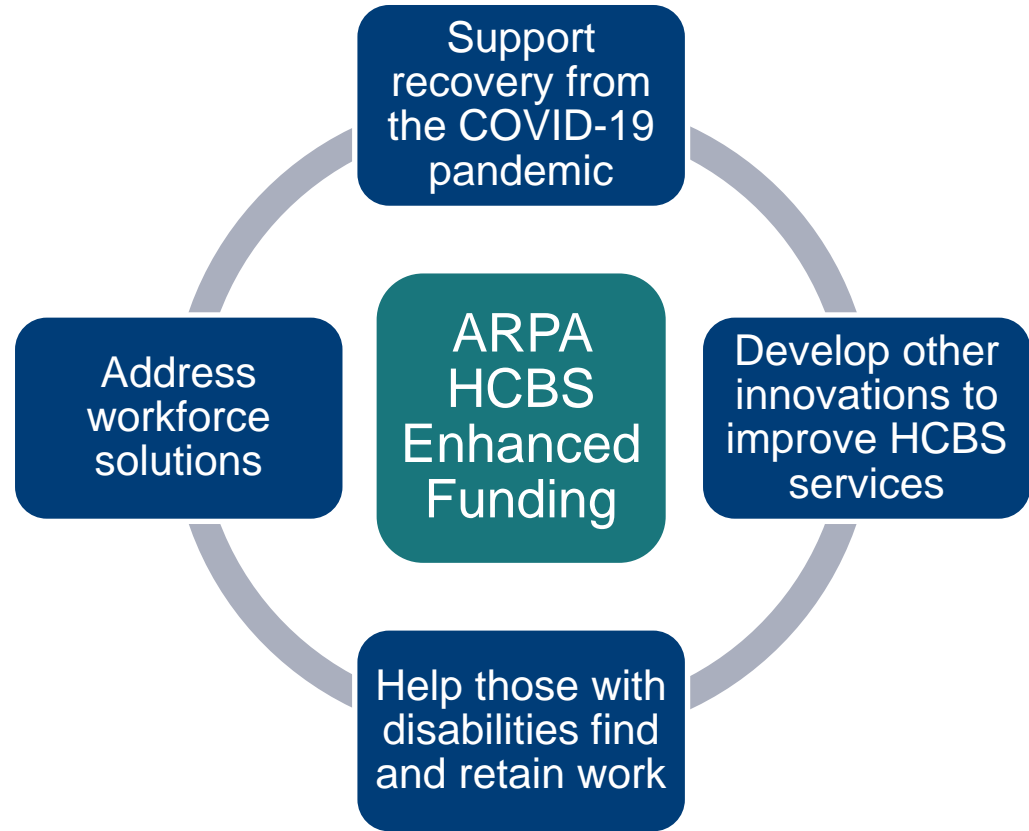





# Objectives

- Fund innovative projects to enhance and support home and community-based services.
- Attack the workforce crisis and other service challenges.
- Target specific efforts that have the best chance for success.

# Eligibility

Entities who support these HCBS programs are eligible to apply for grant funding:

- Children's Long-Term Support
- Family Care
- Family Care Partnership
- IRIS (Include, Respect, I Self-Direct)
- Program for All-Inclusive Care for the Elderly (PACE)

# Vendor Selection

## 1 Management portal

- Design
- Build
- Maintain

## 2 Program operations

- Recruitment
- Application processing
- Tools and resources
- Technical assistance
- Grantee summit
- Success stories

# Timeline

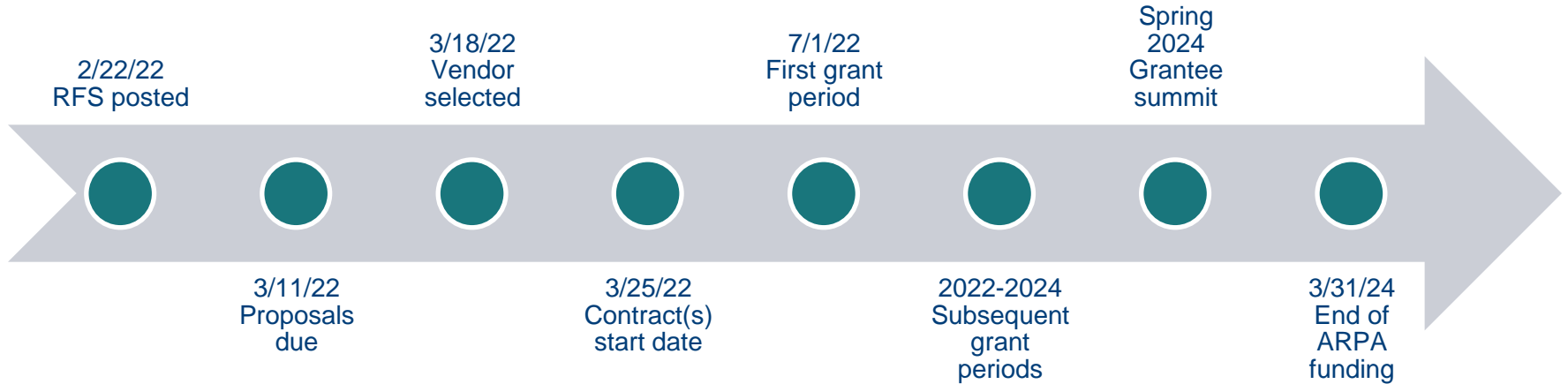

# Council Discussion and Feedback



1. Grant categories or themes
2. Timing and grant periods
3. Scoring rubric
4. Reaching a statewide, diverse audience
5. Other considerations

# Questions?





**WISCONSIN DEPARTMENT**  
*of* **HEALTH SERVICES**

## American Rescue Plan Act of 2021 (ARPA) Section 9817: Expanding, Enhancing, and Strengthening the Home and Community-Based Services Workforce

Kevin Coughlin

Policy Initiatives Advisor – Executive, Benefits and Service Delivery,  
Division of Medicaid Services, Wisconsin Department of Health Services

# Caregiver Crisis By the Numbers

1 in 4

direct caregiver  
positions are vacant

20,000

additional home care  
workers needed by 2024

>50%

Wisconsin's annual  
caregiver turnover



# Impact if the Current Situation Continues

- The 100,000+ beneficiaries in Wisconsin's long-term care system will not get the care they need and deserve.
- As the demand for LTC services continues to grow, the problem will worsen over time.

# Project Goal



- Improve caregiver competencies
- Create a pathway for advancement
- Increase the number of direct care workers
- Improve accountability and sustainability

# Opportunity to Address Systemic Issues

- Lack of competency requirements
- No pathway for advancement
- Low retention rates
- Few processes in place to gauge success or how to improve

# Desired Outcomes

- More choice for those needing care
- Improved HCBS initiatives
- Decreased reliance on LTC system and institutional care options
- Potential cost savings



# Key HCBS Programs

These initiatives will benefit entities and individuals who support these programs:

- Children's Long-Term Support
- Family Care
- Family Care Partnership
- IRIS (Include, Respect, I Self-Direct)
- Program for All-Inclusive Care for the Elderly (PACE)
- FFS Medicaid and BC+ as well as BC+HMO and SSI HMOs

# Staff Stability Survey

Assess the HCBS workforce across Wisconsin

- Direct care workforce participation (FT/PT)
- Turnover
- Worker tenure
- Wages
- Benefits
- Agency recruitment and retention strategies

# Proposed Classification System

Personal Care Workers (PCW) and Supportive Homecare Workers (SHCW)

| Job Tier      | Standards  |
|---------------|--|
| PCW1 or SHCW1 | <ul style="list-style-type: none"><li>• Meets current requirements</li><li>• Work within capacity allowed by Administrative Code</li></ul>           |
| PCW2 or SHCW2 | <ul style="list-style-type: none"><li>• Wisconsin-approved</li><li>• Portable PCW2 and SHCW2 certificate</li><li>• Public registry listing</li></ul> |

# WisCaregiver Careers

Expand successful nursing home CNA program to HCBS providers to attract and retain the workforce

- WisCaregiver branding
- Videos and media campaign
- Website connections and resources
- Tracking system and direct care worker evaluation



# Site Upgrade

- Home and community-based settings
- Training site
- Participating employer map
- Stakeholder page
- Tracking system
- Satisfaction surveys



# Connect Jobseekers to Employers



- Explore [ConnectToCareJobs](#)
- An upgraded version could become Wisconsin's "go-to" site for all things HCBS workforce

# PCW Financial Incentives

- Vouchers for ~7,700 PCW2 certificate programs
- Retention bonus for ~3,800 caregivers
- Eligible recipients:
  - New hires
  - Worked as a PCW for one year
  - Completed a PCW2 certificate

# Provider Incentives

- Incentivize providers to hire workers who have completed new certificate programs
- Incorporate value-based Medicaid direct care Worker payment models and wage approaches to encourage improved competencies and career advancement

# Questions?



# Contact

## Kevin Coughlin

Policy Initiatives Advisor – Executive

Benefits and Service Delivery

Division of Medicaid Services

Wisconsin Department of Health Services



[kevin.coughlin@wi.gov](mailto:kevin.coughlin@wi.gov)



608-509-3398

**ARPA HCBS Updates**  
**As of February 1, 2022**

**Initiative 1: Medicaid HCBS Rate Reform**

- Project 1.1- 5% rate increase for all providers:  
On January 1, 2022 a 5% rate increase was implemented for qualifying home and community-based services regardless of which program is delivering the service. A variety of approaches were utilized to increase fees in various programs. Fee-for-service Medicaid increased the maximum allowable fee schedule, Family Care utilized a directed payment methodology, and IRIS provided agency-based care a 5% rate increase while participants have the authority to allocate the 5% rate increase to their participant hired workers. Further information can be found at: <https://www.dhs.wisconsin.gov/arpa/hcbs-ratereform.htm>
- Project 1.2- Develop a Rate Schedule For Adult HCBS Services and Smooth Implementation of the new Rate Schedule:  
The Department is in the process of developing the scope of work and timeline with an actuarial contractor to start working on this project.

**Initiative 2: Direct Care Workforce (DCW) Reform and Analysis**

- Project 2.1- Direct Care Worker credentialing, registry, training, and differential MA rates:  
This project is still under development and research is being conducted to determine best contracting methods and tools to meet the requirements of this project. Currently the Department is exploring establishing a supportive home care certification and a personal care worker certification.
- Project 2.2- Staff Stability Survey  
The Department is currently exploring survey tools and researching potential questions in order to construct a survey that will result in an accurate assessment of the State's workforce. DHS will initially focus on surveying supportive home care providers and personal care workers to understand current salaries, benefits, turnover rates and other staff stability metrics.

**Initiative 3: Grants to Improve, Enhance and Expend Home and Community Based Services**

- Project 3.1- Grants to Improve, Enhance, and Expand Home and Community Based Services:  
Currently the Department is in the process of acquiring a vendor or vendors to administer a system and administrative process for grant review and fund distribution. It is anticipated that there will be multiple rounds of grants provided that will focus on different themes to assist the home and community-based system with COVID recovery and to improve, enhance and expand Medicaid home and community-based services.

**Initiative 4: Tribal Long Term Care System Enhancements**

- Project 4.1- Tribal Aging and Disability Resource Specialists  
The Department is in the process of developing the amendment to the State/Tribal Contract to add funding so that each tribe can have a tribal aging and disability resource specialist.
- Project 4.2- Tribal Long Term Care System Enhancements  
The Department recently completed the process of surveying each tribe to identify their home and community-based service system needs. The Department is currently reviewing the

findings, and will work with each tribe address their needs to develop a plan to meet those needs and how the ARPA HCBS funds can be used to meet those needs.

### **Initiative 5: Independent Living Pilot and Caregiver Assessment**

- Project 5.1- Independent Living Pilot  
The Department is currently in the process of conducting stakeholder outreach regarding this pilot and an internal workgroup has been convened to develop a concept paper. There are significant considerations for this pilot which need to be discussed including how large the pilot should be, who will administer the program, who is eligible, and what the benefit package should be for the program. As previously mentioned, the Department has held a meeting with advocates to discuss this initiative and the Long-Term Care Council has had a discussion on this pilot.
- Project 5.2- Unpaid caregiver assessment  
This project is still under development

### **Initiative 6: Virtual ADRC and ADRC Outreach and Education**

- Project 6.1- Virtual Aging and Disability Resource Platform; ADRC Outreach and Education  
The internal kickoff meeting for this initiative occurred in January and the Department is in the process of creating a plan for enhancing ADRC outreach and education.

### **Initiative 7: Access for Children**

- Project 7.1- Access to Services for Children with Special Needs  
The scope for this project has been defined to include Children's Long Term Supports program, the Birth to 3 program, Children's Community Options program, and the Katie Becket program. In addition, the initiative will initially focus on identification of children newly identified with special needs that need to find access to these programs. Currently, the Department is in the process of selecting a marketing firm to assist with branding and material development.

### **Initiative 8: Assisted Living Reporting, Member Assessment and Certification**

- Project 8.1- Assisted Living Reporting Tool/ Survey; Member Assessment; 1-2 Bed AFH Certification:  
This project is still under development. This project may be broken out into further projects as it is developed.

### **Initiative 9: Adult and Child Protective Services Enhancements**

- Project 9.1 Adult Critical Incidents System:  
The initial scope of this project will include the adult long term care system. The Department has drafted a concept paper regarding system functionality, and will use this framework to identify a vendor to develop the system.